



Industrial Shock Absorbers

ORIGA – simply the first

aerospace
climate control
electromechanical
filtration
fluid & gas handling
hydraulics
pneumatics
process control
sealing & shielding



ENGINEERING YOUR SUCCESS.

Information on application

The contents of this catalogue are not binding and are only intended for informational purposes and are not to be considered as offer with legal effect. A written confirmation of order from ORIGA is authoritative for the conclusion of a contract; this confirmation is given solely under the respective currently applicable ORIGA General Terms of Sale and Delivery. These are included in our price list and in the Internet at www.parker-origa.com.

All the products presented in this catalogue are purely for commercial use. None of the information or contents is appropriate for private consumers. Private consumers cannot place orders based on the information in the catalogue. Please contact ORIGA for further information.

All the products listed in this catalogue are designed for typical pneumatic applications which e.g. are installed in higher-level machines. The recognized technical rules for safe and expert work are to be observed for the use and installation of pneumatic products. The precondition for the use of the products is, unless stated otherwise, correctly prepared compressed air free from aggressive media. Furthermore, the respective regulations of the legislator, the TÜV (Technical Inspection Association), the respective professional associations or the VDE (Association of Electrical, Electronic and Information Technologies) provisions also apply.

The technical data stated in this catalogue is to be observed by the user. The data stated may not be exceeded nor fallen short of. If such data is not stated then it may be assumed that there are no such upper or lower limits or restrictions for particular applications. In the case of unusual physical or chemical applications, consultation and clearances are to be obtained from ORIGA.

Unless otherwise agreed in individual cases, the customer or end consumer is responsible for the disposal of the ORIGA products. Disposal by ORIGA is not included in the price and this would have to be taken into account in the event of any applicable return to and disposal by ORIGA.

Technical data and representations

The technical data and illustrations have been compiled with great care and to the best of our knowledge. We cannot assume any guarantee for the up-to-dateness, correctness and completeness of the information.

The data and information such as illustrations, drawings, descriptions, dimensions, weights, materials, technical and other performances as well as the products and services described in general product descriptions, ORIGA catalogues, brochures and price lists of any type are subject to change and may be modified or updated at any time without prior announcement by ORIGA. They are only binding in so far as the contract or confirmation of order expressly refers to them. Slight deviations from such product descriptions are deemed as approved and do not affect the fulfillment of contracts in so far as these are considered acceptable to customers.

This catalogue does not contain any guarantees, assured characteristics or agreements on condition by ORIGA for the products represented, neither expressly nor implicitly, nor with regard to the availability of the products. Advertising statements regarding quality characteristics, properties or applications of ORIGA products are without legal obligation.

As far as legally permissible, any liability is excluded on the part of ORIGA for direct or indirect damage, consequential damage, claims of any type and on any legal basis arising from the use of the information contained in this catalogue.

Trademarks, copyright and reproduction

The representation of industrial rights such as brands, logos, registered trademarks or patents in this catalogue does not include the granting of licenses or rights of use. The use of these is not permitted without the express consent of ORIGA. The entire contents of this catalogue are the intellectual property of ORIGA. Within the meaning of copyright, any unlawful use of intellectual property, even extracts, is prohibited. Reprinting, reproduction and translation (even extracts) are only permitted with the prior written consent of ORIGA.

Importance of EU Directives

Various Directives have been issued by the EU Commission in the course of the unification of the single European market; the following Directives are in part of significance for ORIGA products:

- Simple pressure vessels (87/404/EWG, amended by 90/488/EWG and 93/68/EWG)
- Low-voltage electrical equipment (73/23/EWG, amended by 93/68/EWG)
- Machinery Directive (89/392/EWG, amended by 91/368/EWG, 93/44/ EWG and 98/37/EG)
- Pressure Equipment Directive (97/23/EWG)
- Equipment and protective systems intended for use in potentially explosive atmospheres (ATEX Directive, 94/9/EG)
- Electromagnetic Compatibility Directive (EMV Directive, 89/336/EWG, amended by 92/31/EWG)

If a product comes within the scope of application of one of these Guidelines, then an EU Declaration of Conformity with CE mark (CE for Communauté Européenne) is required. This CE marking does not represent a quality feature but verifies that the conformity assessment procedure specified has been concluded successfully and the protective requirements of the relevant EU Directives have been observed.

Products which do not come under any of the above mentioned Directives may not bear the CE mark nor may any manufacturer's declaration according to the EU Machinery Directive or Declaration of Conformity be issued for these products.

If a product may not be CE marked according to the Machinery Directive, it must however be marked if it comes within the scope of application of any other Directive.

The following harmonized standards are applied in the design of ORIGA components and systems:

- DIN EN ISO 12100 Safety of machinery
- DIN EN 60204.1 Electrical equipment of machines
- DIN EN 983 Safety requirements for fluid power systems and their components

The following Directives are of particular significance to ORIGA:

- ORIGA products in potentially explosive atmospheres, to which the above mentioned ATEX Directive applies, are treated according to the Directive and CE and EX marked.
- According to the Machinery Directive, ORIGA products are mainly components for installation in machines and therefore do not require an EU Declaration of Conformity with CE mark. Parker-Origa issues a manufacturer's declaration according to the Machinery Directive for these components. This declaration corresponds to a great extent to the Declaration of Conformity with the comment that commissioning is only permitted if the machine or system conforms to the Directives. This manufacturer's declaration impacts neither our product liability based on the product liability law nor warranty assurances according to our General Terms of Sale and Delivery. Neither does the manufacturer's declaration affect our quality assurance measures according to our Quality Management Manual nor our quality certification according to ISO 9001.
- According to the Pressure Equipment Directive, ORIGA products are components of low hazard potential, thus most of the products do not come under this Directive. The exceptions to this are maintenance equipment from a certain pressure/volume level onwards. These components are treated according to the Directive if required and bear the CE mark.

ORIGA products are excluded from the following EU Guidelines:

- End-of-life vehicles (2000/53/EG).
- Waste Electronic and Electrical equipment (WEEE, 2002/96/EG) and Restriction on Hazardous Substances (RoHS, 2002/95/EG).
- Pressure Equipment Directive (97/23/EWG) with the above mentioned exceptions.

Table of Contents

Industrial Shock Absorber

	Page
Technical informations	4
Survey	16
Non-adjustable Shock Absorber	
Type SA 10 N, SA 10 SN, SA 10 S2N	20
Type SA 12N, SA 12 SN, SA 12 S2N	22
Type SA 14, SA 14S, SA 14S2	24
Type SA 20, SA 20S, SA 20S2	27
SA 20x25, SA 20Sx25, SA 20S2x25	
Type SAI 25, SAI 25S,	30
Type SA 33, SA 33S, SA 33S2, SA 33S3	33
Type SA 45, SA 45S, SA 45S2, SA 45S3	37
Type SA 64, SA 64S, SA 64 S2, SA64S3	41
Adjustable Shock Absorber	
Type SA 1/4 x 1/2N	44
Type SA 3/8 x 1D	46
Type SA 1/2 x 1M, SA 1/2 x 2M	48
Type SA 1/2 x 1, SA 1/2 x 2	51
Type SA 3/4 x 1, SA 3/4 x 2, SA 3/4 x 3	55
Type SA 1 1/8 x 2, SA 1 1/8 x 4	59
Type SA -A 3/4 x 1, SA 3/4 x 2, SA 3/4 x 3	63
Type SA-A 1 1/8 x 2, SA -A 1 1/8 x 4, SA -A 1 1/8 x 6	67

Industrial Shock Absorbers

Adjustable

Non-adjustable



Smooth, Controlled Stopping of Moving Loads

ORIGA shock absorbers prevent damage to moving parts and to machines and plant, destructive impact forces are absorbed by controlled linear deceleration.

ORIGA shock absorbers let you

- increase operating speeds
- increase operating loads
- increase system performance
- increase operating reliability
- reduce stresses on equipment
- reduce production costs
- reduce noise levels

All moving parts in a production process have to be stopped without damage to themselves or to the stopping devices of the machines and plant.

The high impact forces have to be reduced in a controlled manner: to bring a moving load to a standstill, the kinetic energy generated by the movement has to be dissipated.

The heavier the moving load and the faster it moves, the higher the kinetic energy. In automation especially, shorter and shorter cycle times are demanded, so that stopping times are greatly reduced while kinetic energy levels are dramatically increased. These again have to be dissipated in a controlled manner. Some commonly used stop-ping devices such as springs, rubber buffers or dash-pots actually increase shock loading instead of reducing it – they do not dissipate energy at a uniform rate. For smooth dissipation of the kinetic energy we recommend the use of hydraulic shock absorbers.

ORIGA shock absorbers convert the kinetic energy generated by the deceleration of the load into thermal energy. Optimum operating conditions are achieved if the energy is dissipated almost uniformly, i.e. if the moving mass is brought to a halt in the shortest distance, in the shortest time and without sudden peak loads during the stroke.

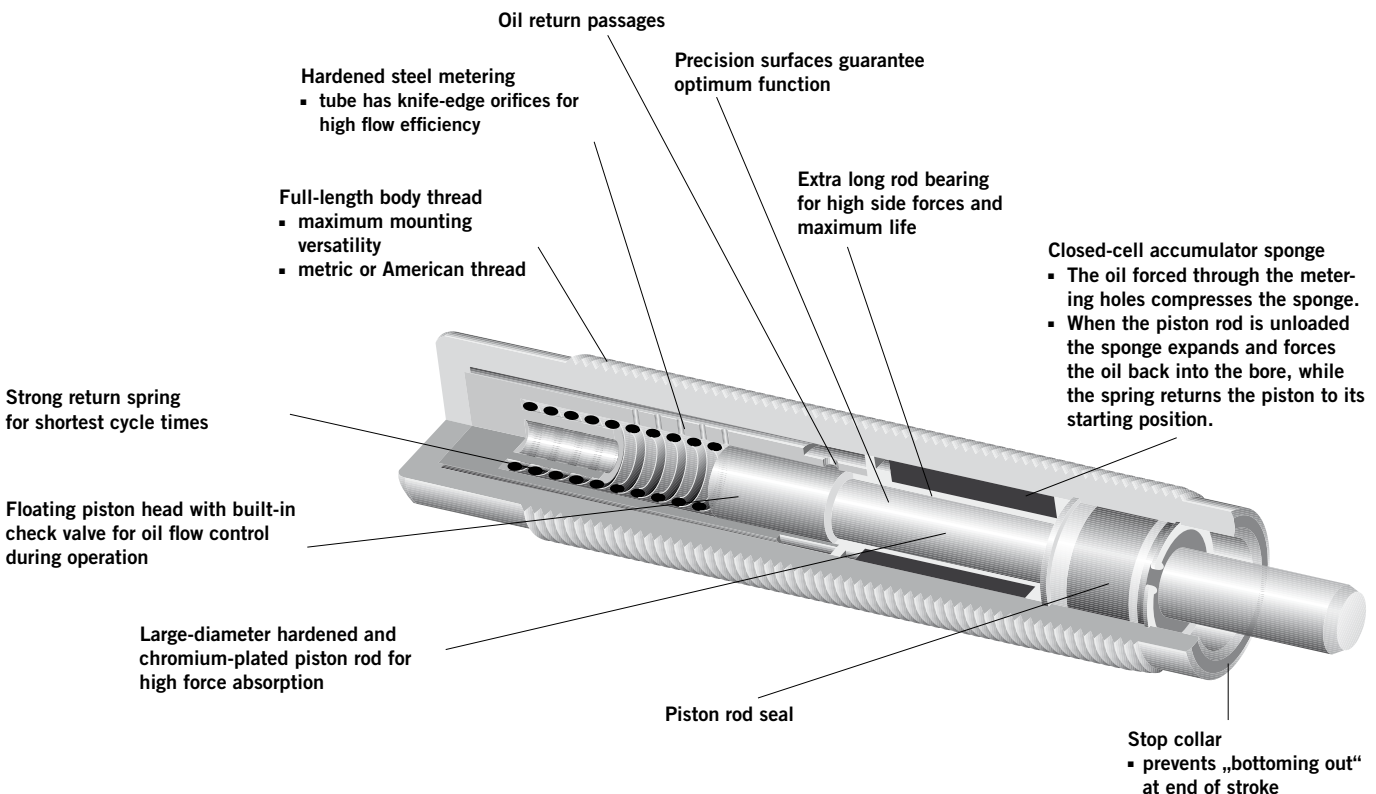

A Wide Range of Applications

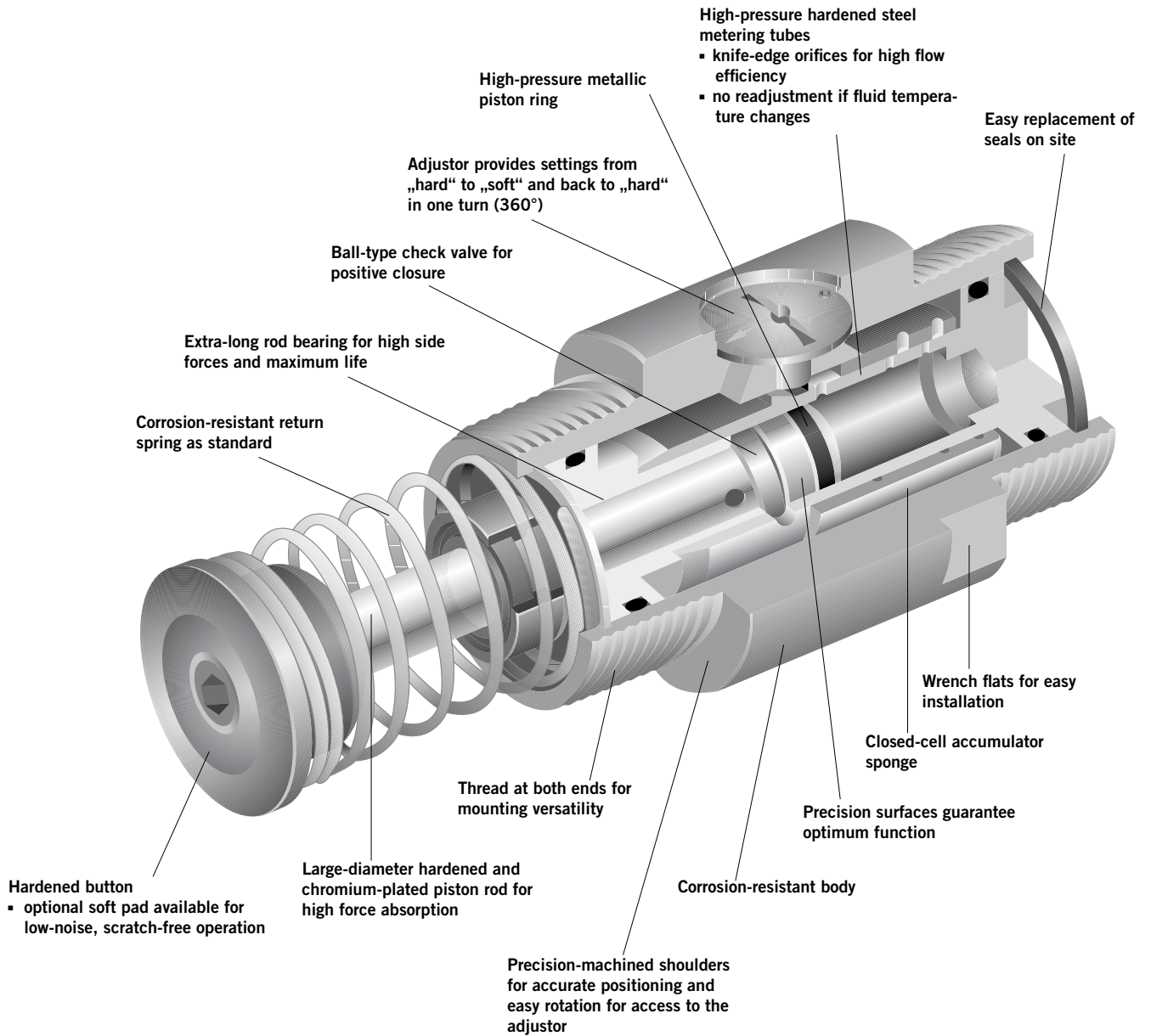

Simplify your design work by installing our shock absorber dimensions on your system. The file is compatible with all popular CAD systems.

Shock Absorption

Ordinary shock absorbers, springs, buffers and pneumatic cushioning cannot match the performance of ORIGA shock absorbers.

These shock absorbers match the speed and mass of the moving object and bring it smoothly and uniformly to rest.

Springs and buffers, on the other hand, store energy rather than dissipate it.

Although the moving object is stopped, it bounces back and this leads to fatigue in materials and components which can cause premature breakdown of the machine.

Pneumatic cushioning provides a better solution because the energy is actually converted, but because of the compressibility of air the maximum braking force is generated at the end of the stroke, which can lead to excessive loads on components.

Hydraulic dashpots also cause excessive loads because peak resistance comes at the beginning of the stroke and then quickly falls away. This generates unnecessarily high braking forces.

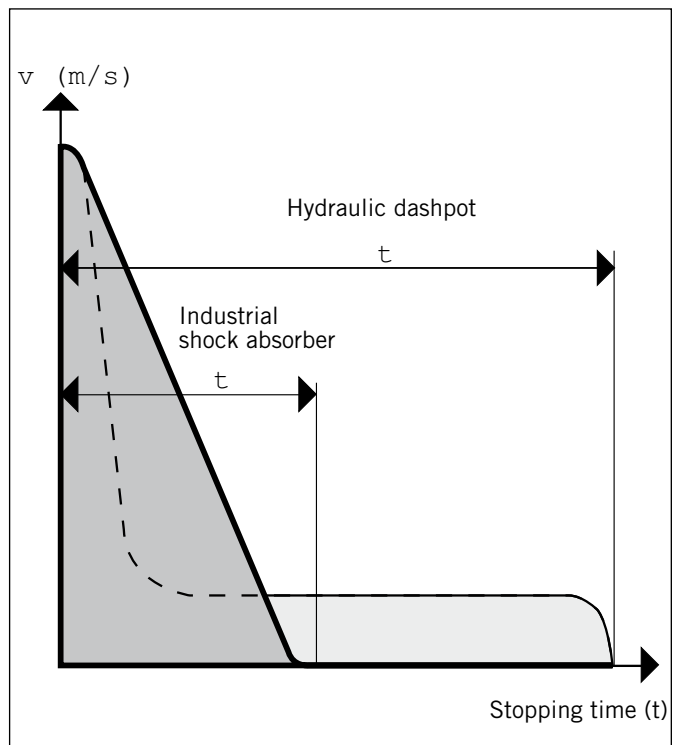
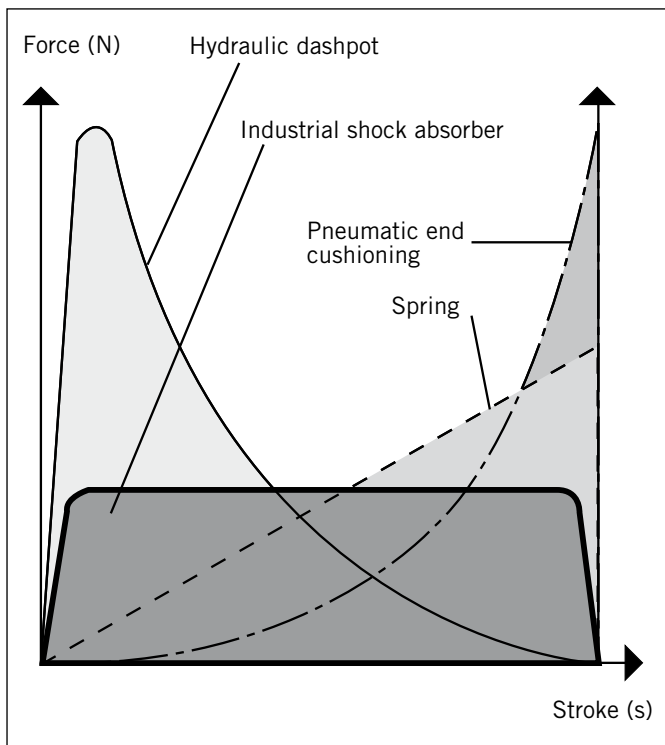

The Force/Stroke Diagram

clearly shows these effects. The shock absorber curve is ideal because all the energy is dissipated by linear deceleration without initial impact or final rebound.

Stopping Time

Both damping units stop the same mass from the same speed with the same stroke. Therefore they do the same work but the industrial shock absorber reduces the stopping time by 60 to 70 %.

Selection of Shock Absorber Type

ORIGA shock absorbers are available in two main types, to suit different applications and installation requirements. After selection of the appropriate type, sizing is determined by calculation.

Compact series with full-length body thread

This compact, space-saving series is available in adjustable and non-adjustable versions and can be installed in many different ways, e.g. in a tapped blind hole, in a tapped through-hole, in a clearance hole in a flange or bracket, etc.



Universal series

This versatile, adjustable series with various mounting accessories is designed to stop heavier loads. It is especially suited to applications which require several of the same shock absorbers with the same stroke length.



Mounting methods

ORIGA shock absorbers are designed for a variety of mountings, which can be either built into machines or supplied as accessories.

Accumulators

Normally shock absorbers with internal accumulators are used. This simplifies installation by eliminating external piping and oil storage.

However, in applications with short cycle times and high kinetic energy the oil can become overheated. In this case an external accumulator should be used so that the oil can be cooled in the external circuit.

Shock absorber return stroke

- Piston rod with return spring combined with internal accumulator
- Return stroke actuated by compressed air or mechanically, combined with external accumulator. With this version a delayed return stroke is also possible.

Options

- Stop collars for front or rear mounting – these provide a positive stop to prevent damage caused by the piston „bottoming out“. They also allow precise setting of the stroke length.
- Soft pad for the hardened steel button – to avoid surface damage and reduce noise levels.

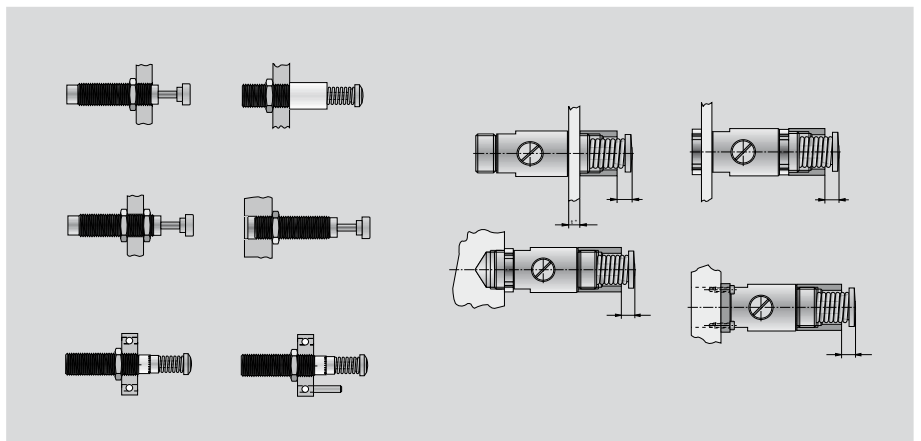

The Selection of Shock Absorbers

Correct choice of shock absorber

The type of shock absorber and its mounting method are mainly determined by the application.

In most applications, shock absorbers with internal accumulators are preferred to those with external accumulators.

The reason for this is that shock absorbers with internal accumulators are supplied prefilled with oil and therefore ready for immediate use, whereas shock absorbers with external accumulators require additional equipment, resulting in higher installation costs.

Selection criteria

- Type of shock absorber
 - with internal accumulator
 - with external accumulator including air/oil tank
- Type of piston rod return
 - return spring
 - air or mechanical
- Stroke length
 - Use the longest stroke possible taking any side loads into account.
 - maximum impact force reduction

Accumulators

- Internal accumulator
 - The fluid displaced by the piston compresses a nitrogen-filled, closed-cell sponge.
 - When the piston is unloaded the return spring pushes the piston back to its rest position. At the same time the compressed sponge expands and forces the fluid back into the high pressure chamber.
- External accumulator
 - The use of external accumulators is recommended where high energy conversion is needed or excess heat dissipation is required, e.g. in applications with short cycle times or in high temperature areas.
 - The external accumulator, consisting of

an open or closed tank, is connected to the shock absorber by pipework.

The oil heated in the shock absorber circulates between the tank and the shock absorber and is therefore continuously cooled during operation.

Note:

The tank should always be installed higher than the shock absorber and the connecting pipework should be as short as possible.

If possible there should also be a 10 µm filter between the two units.

If the tank is installed further away from the shock absorber there must be a positive oil circulation system (see diagram) to ensure that the oil actually flows through the tank and is cooled down.

Piston rod return

Piston rod return is actuated by

- Return springs
 - In the self-contained units, a built-in spring returns the piston rod to its rest position when it is unloaded.
 - Air/Oil
 - In units with external accumulators an air/oil system or a mechanical device is used for piston rod return.
 - Mechanical units
 - Mechanical rod return is mostly used in types with a clevis mounting, with actuation by another unit via levers.
- ORIGA SA-A Series shock absorbers feature steplessly adjustable stroke, time-delay damping and adjustable rod return forces.

The SA Series is fitted with return springs as standard. If these types are used with an external accumulator for better heat dissipation, this does not need to be pressurized because the spring returns the rod.

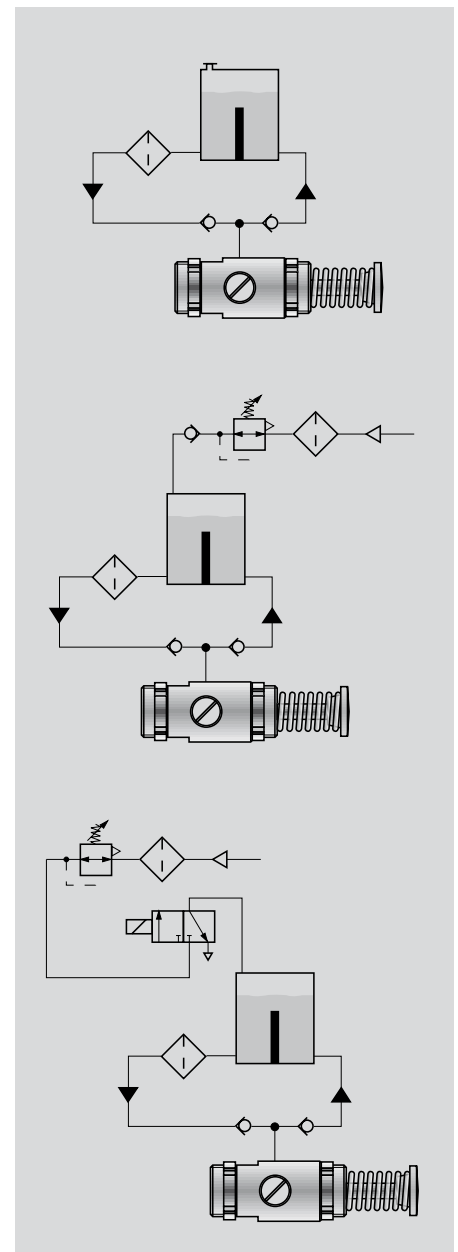

Calculations for Shock Absorber Selection

Selection factors

- How much energy has to be dissipated during each deceleration stroke (cycle)
- How much energy has to be dissipated during one hour of operation
- The Effective Mass

Effective Mass

Effective Mass is a very important factor in correctly sizing a shock absorber. It indicates whether the shock absorber can be adjusted to perform properly. It also prevents under- or over-sizing where propelling forces are involved or velocities are very high or very low.

As a general rule, the next larger size of shock absorber is selected if the impact velocity is under 0.3 m/s and/or the propelling force energy (F x S) exceeds 50 % of the calculated E3 value. The higher the Effective Mass, the higher the impact force at the end of the shock absorber stroke, whereas low Effective Mass generates very high impact forces at the beginning of the stroke. These two points have to be considered in the calculation as they can lead to serious damage over a longer period of time.

Minimum/ maximum Effective Mass is laid down for all ORIGA shock absorbers (see Table page 17). Effective Mass is calculated using the following formula.

$$m_e = \frac{2 \cdot W_3}{vD^2}$$

Symbols

W_1	kinetic energy per stroke; only mass load [Nm]	v^{**}	final speed of mass [m/s]	h	fall height without shock absorber stroke [m]
W_2	energy/work of driving force per stroke [Nm]	vD^{**}	impact speed on shock absorber [m/s]	s	shock absorber stroke [m]
W_3	total energy per stroke ($W_1 + W_2$) [Nm]	ω	angular speed [1/s]	$L/R/r$	radius [m]
W_4^*	total energy per hour ($W_3 \cdot X$) [Nm/h]	F	additional driving force [N]	Q	counterforce/supporting force [N]
m_e	effective mass [kg]	P	motor power [kW]	μ	coefficient of friction
m	mass to be braked [kg]	HM^{***}	holding moment factor (normal 2.5) 1 to 3	t	braking time [s]
n	number of shock absorbers (parallel)	M	torque [Nm]	a	deceleration [m/s ²]
		J	mass moment of inertia [kgm ²]	α	angle of impact [°]
		g	acceleration due to gravity = 9.81 [m/s ²]	β	angle [°]

*The permissible W_4 values shown in the performance tables are valid only at room temperature. At higher ambient temperatures, lower values would apply.

**v or vD is the final speed of the mass. Therefore for accelerated movement an additional 50 - 100% on average speed should be taken into account.

***HM \triangleq relationship of starting torque to nominal torque of motor (depending on type).

Counterforce/supporting force Q [N]

The following applies to all examples:

$$Q = \frac{1.5 \cdot W_3}{s}$$

Braking time [s]

The following applies to all examples:

$$Q = \frac{2.6 \cdot s}{vD}$$

Deceleration a [m/s²]

The following applies to all examples:

$$Q = \frac{0.75 \cdot vD^2}{s}$$

Examples of Calculations for Shock Absorber Selection

Mass without driving force

Formular

$$\begin{aligned} W_1 &= m \cdot v^2 \cdot 0.5 \\ W_2 &= 0 \\ W_3 &= W_1 + W_2 \\ W_4 &= W_3 \cdot X \\ vD &= v \\ m_e &= m \end{aligned}$$

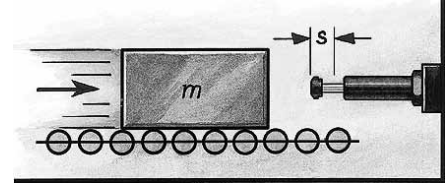

Example

$m = 100 \text{ kg}$	$W_1 = 100 \cdot 1.5^2 \cdot 0.5$	$= 113 \text{ Nm}$
$v = 1.5 \text{ m/s}$	$W_2 = 0$	
$x = 500 \text{ 1/h}$	$W_3 = 113 + 0$	$= 113 \text{ Nm}$
$s = 0.050 \text{ m}$	$W_4 = 113 \cdot 500$	$= 56.500 \text{ Nm/h}$
(selected)	$m_e = m$	$= 100 \text{ kg}$

Mass with driving force

Formular

$$\begin{aligned} W_1 &= m \cdot v^2 \cdot 0.5 \\ W_2 &= 0 \\ W_3 &= W_1 + W_2 \\ W_4 &= W_3 \cdot X \\ vD &= v \end{aligned}$$

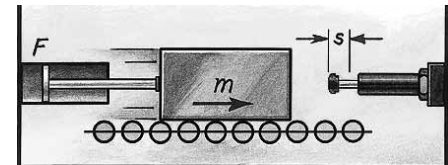

$$m_e = \frac{2 \cdot W_3}{vD^2}$$

with vertical movement upwards:

$$W_2 = (F - m \cdot g) \cdot s$$

with vertical movement downwards:

$$W_2 = (F + m \cdot g) \cdot s$$

Example

$m = 36 \text{ kg}$	$W_1 = 36 \cdot 1.5^2 \cdot 0.5$	$= 41 \text{ Nm}$
$*v = 1.5 \text{ m/s}$	$W_2 = 400 \cdot 0.025$	$= 10 \text{ Nm}$
$F = 400 \text{ N}$	$W_3 = 41 + 10$	$= 51 \text{ Nm}$
$x = 1000 \text{ 1/h}$	$W_4 = 51 \cdot 1000$	$= 51.000 \text{ Nm/h}$
$s = 0.025 \text{ m}$	$m_e = 2 \cdot 51 : 1.5^2$	$= 45 \text{ kg}$
(selected)		

*v is the final speed of the mass: therefore with pneumatic drive an additional 50 - 100% on average speed should be taken into account.

Mass with motor drive (interlocking)

Formula

$$\begin{aligned} W_1 &= m \cdot v^2 \cdot 0.5 \\ W_2 &= \frac{1000 \cdot P \cdot HM \cdot s}{v} \\ W_3 &= W_1 + W_2 \\ W_4 &= W_3 \cdot X \\ vD &= v \\ m_e &= \frac{2 \cdot W_3}{vD^2} \end{aligned}$$

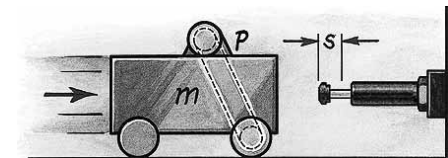

Example

$m = 800 \text{ kg}$	$W_1 = 800 \cdot 1.2^2 \cdot 0.5$	$= 576 \text{ Nm}$
$v = 1.2 \text{ m/s}$	$W_2 = 1000 \cdot 4 \cdot 2.5 \cdot 0.1 : 1.2$	$= 834 \text{ Nm}$
$HM = 2.5$	$W_3 = 576 + 834$	$= 1.410 \text{ Nm}$
$P = 4 \text{ kW}$	$W_4 = 1410 \cdot 100$	$= 141.000 \text{ Nm/h}$
$x = 100 \text{ 1/h}$	$m_e = 2 \cdot 1410 : 1.2^2$	$= 1958 \text{ kg}$
$s = 0.100 \text{ m}$		
(selected)		

Note: rotation energies of motor, clutch and gearbox, if not negligible, should be added to W_1 .

**Mass on driven rollers
(frictionally engaged)**

Formular

$$W_1 = m \cdot v^2 \cdot 0.5$$

$$W_2 = m \cdot \mu \cdot g \cdot s$$

$$W_3 = W_1 + W_2$$

$$W_4 = W_3 \cdot X$$

$$vD = v$$

$$me = \frac{2 \cdot W_3}{vD^2}$$

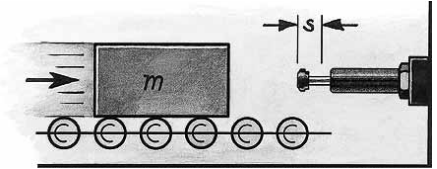

Example

$m = 250 \text{ kg}$	$W_1 = 250 \cdot 1.5^2 \cdot 0.5$	$= 281 \text{ Nm}$
$v = 1.5 \text{ m/s}$	$W_2 = 250 \cdot 0.2 \cdot 9.81 \cdot 0.05$	$= 25 \text{ Nm}$
$x = 180 \text{ 1/h}$	$W_3 = 281 + 25$	$= 306 \text{ Nm}$
(steel/cast iron)	$W_4 = 306 \cdot 180$	$= 55.080 \text{ Nm/h}$
$\mu = 0.2$	$me = 2 \cdot 306 : 1.5^2$	$= 272 \text{ kg}$
$s = 0.050 \text{ m}$ (selected)		

Swivelling mass with drive torque

Formular

$$W_1 = m \cdot v^2 \cdot 0.5 = 0.5 \cdot J^2$$

$$W_2 = \frac{M \cdot s}{R}$$

$$W_3 = W_1 + W_2$$

$$W_4 = W_3 \cdot X$$

$$vD = \frac{v \cdot R}{L} = \cdot R$$

$$me = \frac{2 \cdot W_3}{vD^2}$$

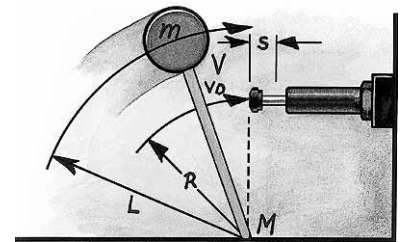

Example

$m = 20 \text{ kg}$	$W_1 = 20 \cdot 1^2 \cdot 0.5$	$= 10 \text{ Nm}$
$v = 1 \text{ m/s}$	$W_2 = 50 \cdot 0.012 : 0.5$	$= 1.2 \text{ Nm}$
$M = 50 \text{ Nm}$	$W_3 = 10 + 1.2$	$= 11.2 \text{ Nm}$
$R = 0.5 \text{ m}$	$W_4 = 11.2 \cdot 1500$	$= 16.800 \text{ Nm/h}$
$L = 0.8 \text{ m}$	$vD = 1 \cdot 0.5 : 0.8$	$= 0.63 \text{ m/s}$
$x = 1500 \text{ 1/h}$	$me = 2 \cdot 11.2 : 0.63^2$	$= 56 \text{ kg}$
$s = 0.012 \text{ m}$ (selected)	Please adjust angle of impact $\tan \alpha = s/R$ with the table entry „max. deviation from axis“ (see example 6.2)	

Free falling mass

Formular

$$W_1 = m \cdot g \cdot h$$

$$W_2 = m \cdot g \cdot s$$

$$W_3 = W_1 + W_2$$

$$W_4 = W_3 \cdot X$$

$$vD = \sqrt{2 \cdot g \cdot h}$$

$$me = \frac{2 \cdot W_3}{vD^2}$$

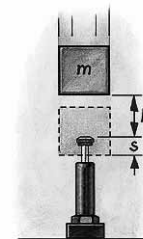

Example

$m = 30 \text{ kg}$	$W_1 = 30 \cdot 0.5 \cdot 9.81$	$= 147 \text{ Nm}$
$h = 0.5 \text{ m}$	$W_2 = 30 \cdot 9.81 \cdot 0.05$	$= 15 \text{ Nm}$
$x = 400 \text{ 1/h}$	$W_3 = 147 + 15$	$= 162 \text{ Nm}$
$s = 0.050 \text{ m}$ (selected)	$W_4 = 162 \cdot 400$	$= 64.800 \text{ Nm/h}$
	$vD = \sqrt{2 \cdot 9.81 \cdot 0.5}$	$= 3.13 \text{ m/s}$
	$me = \frac{2 \cdot 162}{3.13^2}$	$= 33 \text{ kg}$

Examples of Calculations for Shock Absorber Selection

Rotary table with drive torque
horizontal or vertical

Formula

$$W_1 = m \cdot v^2 \cdot 0.25 = 0.5 \cdot J^2$$

$$W_2 = \frac{M \cdot s}{R}$$

$$W_3 = W_1 + W_2$$

$$W_4 = W_3 \cdot X$$

$$vD = \frac{v \cdot R}{L} = \cdot R$$

$$me = \frac{2 \cdot W_3}{vD}$$

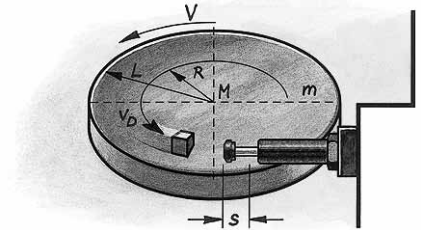

Example

$$m = 1000 \text{ kg}$$

$$v = 1.1 \text{ m/s}$$

$$M = 1000 \text{ Nm}$$

$$s = 0.050 \text{ m}$$

(selected)

$$L = 1.25 \text{ m}$$

$$R = 0.8 \text{ m}$$

$$x = 100 \text{ 1/h}$$

$$W^1 = 1000 \cdot 1.1^2 \cdot 0.25 = 303 \text{ Nm}$$

$$W^2 = 1000 \cdot 0.05 : 0.8 = 63 \text{ Nm}$$

$$W^3 = 303 + 63 = 366 \text{ Nm}$$

$$W^4 = 366 \cdot 100 = 36.600 \text{ Nm/h}$$

$$vD = 1.1 \cdot 0.8 : 1.25 = 0.7 \text{ m/s}$$

$$me = 2 \cdot 366 : 0.7^2 = 1.494 \text{ kg}$$

Please adjust angle of impact $\tan \alpha = s/R$ with the table entry
„max. deviation from axis“ (see example 6.2)

Swivelling mass with drive torque
(e.g. turntable)

Formula

$$W_1 = m \cdot v^2 \cdot 0.17 = 0.5 \cdot J^2$$

$$W_2 = \frac{M \cdot s}{R}$$

$$W_3 = W_1 + W_2$$

$$W_4 = W_3 \cdot X$$

$$vD = \frac{v \cdot R}{L} = \cdot R$$

$$me = \frac{2 \cdot W_3}{vD^2}$$

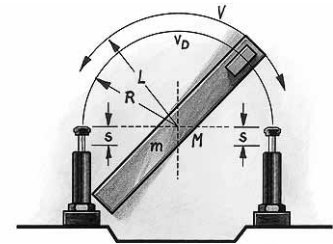

Example

$$J = 56 \text{ kgm}^2$$

$$= 1 \text{ 1/s}$$

$$M = 300 \text{ Nm}$$

$$s = 0.025 \text{ m}$$

(selected)

$$L = 1.5 \text{ m}$$

$$R = 0.8 \text{ m}$$

$$x = 1200 \text{ 1/h}$$

$$W_1 = 0.5 \cdot 56 \cdot 1^2 = 28 \text{ Nm}$$

$$W_2 = 300 \cdot 0.025 : 0.8 = 9 \text{ Nm}$$

$$W_3 = 28 + 9 = 37 \text{ Nm}$$

$$W_4 = 37 \cdot 1200 = 44.400 \text{ Nm/h}$$

$$vD = 1 \cdot 0.8 = 0.8 \text{ m/s}$$

$$me = 2 \cdot 37 : 0.8^2 = 116 \text{ kg}$$

Please adjust angle of impact $\tan \alpha = s/R$ with the table entry
„max. deviation from axis“ (see example 6.2)

Swivelling mass with drive arrangement

Formula

$$W_1 = m \cdot v^2 \cdot 0.17 = 0.5 \cdot J^2$$

$$W_2 = \frac{F \cdot r \cdot s}{R} = \frac{M \cdot s}{R}$$

$$W_3 = W_1 + W_2$$

$$W_4 = W_3 \cdot X$$

$$vD = \frac{v \cdot R}{L} = \cdot R$$

$$me = \frac{2 \cdot W_3}{vD^2}$$

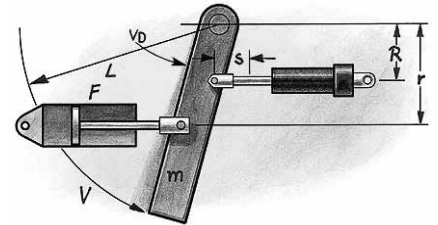

Example

$$m = 1000 \text{ kg}$$

$$v = 2 \text{ m/s}$$

$$F = 7000 \text{ N}$$

$$M = 4200 \text{ Nm}$$

$$s = 0.050 \text{ m}$$

(selected)

$$r = 0.6 \text{ m}$$

$$R = 0.8 \text{ m}$$

$$L = 1.2 \text{ m}$$

$$x = 900 \text{ 1/h}$$

$$W_1 = 1000 \cdot 2^2 \cdot 0.18$$

$$W_2 = 7000 \cdot 0.6 \cdot 0.05 : 0.8$$

$$W_3 = 720 + 263$$

$$W_4 = 983 \cdot 900$$

$$vD = 2 \cdot 0.8 : 1.2$$

$$me = 2 \cdot 983 : 1.33^2$$

$$= 720 \text{ Nm}$$

$$= 263 \text{ Nm}$$

$$= \underline{983 \text{ Nm}}$$

$$= \underline{884.700 \text{ Nm/h}}$$

$$= 1.33 \text{ m/s}$$

$$= \underline{1.111 \text{ kg}}$$

Falling mass without drive force

Formula

$$W_1 = m \cdot v^2 \cdot 0.17 = 0.5 \cdot J^2$$

$$W_2 = \frac{M \cdot s}{R}$$

$$W_3 = W_1 + W_2$$

$$W_4 = W_3 \cdot X$$

$$vD = \frac{v \cdot R}{L} = \cdot R$$

$$me = \frac{2 \cdot W_3}{vD^2}$$

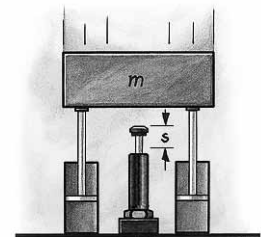

Example

$$m = 6000 \text{ kg}$$

$$v = 1.5 \text{ m/s}$$

$$s = 0.305 \text{ m}$$

(selected)

$$x = 60 \text{ 1/h}$$

$$W_1 = 6000 \cdot 1.5^2 \cdot 0.5$$

$$W_2 = 6000 \cdot 9.81 \cdot 0.305$$

$$W_3 = 6750 + 17952$$

$$W_4 = 24702 \cdot 60$$

$$me = 2 \cdot 24702 : 1.52$$

$$= 6.750 \text{ Nm}$$

$$= 17.952 \text{ Nm}$$

$$= \underline{24.702 \text{ Nm}}$$

$$= \underline{1.482.120 \text{ Nm/h}}$$

$$= \underline{21.957 \text{ kg}}$$

Examples of Calculations for Shock Absorber Selection

Mass on sloping surface

Formula

$$W_1 = m \cdot v^2 \cdot h = m \cdot v_D^2 \cdot 0.5$$

$$W_2 = m \cdot g \cdot \sin \cdot s$$

$$W_3 = W_1 + W_2$$

$$W_4 = W_3 \cdot X$$

$$vD = \sqrt{2 \cdot g \cdot h}$$

$$me = \frac{2 \cdot W_3}{vD^2}$$

with drive force upwards:

$$W_2 = (F - m \cdot g \cdot \sin) \cdot s$$

with drive force downwards:

$$W_2 = (F + m \cdot g \cdot \sin) \cdot s$$

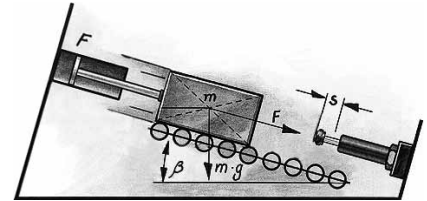

Mass freely swinging on pivot

Formula

Calculation like „mass on sloping surface“, but:

$$W_2 = 0$$

$$W_1 = m \cdot g \cdot h$$

$$vD = \sqrt{2 \cdot g \cdot h} \cdot \frac{R}{L}$$

Please adjust angle of impact $\tan \alpha = s/R$ with the table entry „max. deviation from axis“.

Axial deviation from shock absorber axis

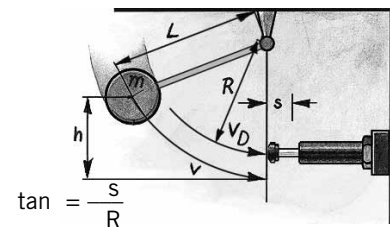

Effective Mass m_e

Mass without drive force

Formula: $m_e = m$

Example:

$$m = 100 \text{ kg}$$

$$vD = v = 2 \text{ m/s}$$

$$W_1 = W_3 = 200 \text{ Nm}$$

$$m_e = \frac{2 \cdot 200}{4} = 100 \text{ kg}$$

$$m_e = m$$

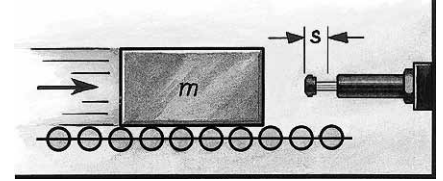

Mass with drive force

Formula: $\frac{2 \cdot W^3}{vD^2}$

Example:

$$m = 100 \text{ kg}$$

$$F = 2000 \text{ N}$$

$$vD = v = 2 \text{ m/s}$$

$$s = 0.1 \text{ m}$$

$$W_1 = 200 \text{ Nm}$$

$$W_2 = 200 \text{ Nm}$$

$$W_3 = 400 \text{ Nm}$$

$$m_e = \frac{2 \cdot 400}{4} = 200 \text{ kg}$$

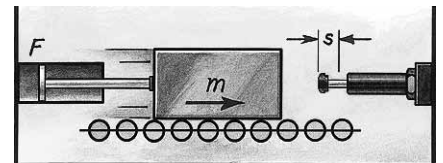

Mass without drive force
direct onto shock absorber

Formula: $m_e = m$

Example:

$$m = 20 \text{ kg}$$

$$vD = v = 2 \text{ m/s}$$

$$s = 0.1 \text{ m}$$

$$W_1 = W_3 = 40 \text{ Nm}$$

$$m_e = \frac{2 \cdot 40}{2^2} = 20 \text{ kg}$$

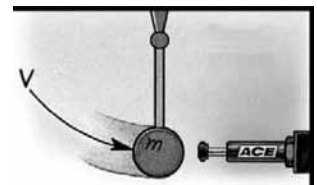

Mass without drive force
with lever transmission

Formula: $\frac{2 \cdot W^3}{vD^2}$

Example:

$$m = 20 \text{ kg}$$

$$F = 2000 \text{ N}$$

$$v = 2 \text{ m/s}$$

$$vD = 0.5 \text{ m/s}$$

$$W_1 = W_3 = 40 \text{ Nm}$$

$$m_e = \frac{2 \cdot 40}{0.5^2} = 320 \text{ kg}$$

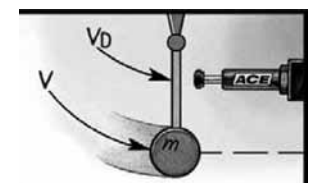

The effective mass (m_e) can be the actual moving mass or an equivalent mass for the drive force or transmission + the actual mass.

Overview of Non-Adjust- able Shock Absorbers

Non-Adjustable Shock Absorbers

Type	Stroke (mm)	Effective Mass m_e (kg)		Max Energy Absorption (Nm)		Thread Size	Page
		Min.	Max.	per stroke W_3	per hour W_4		
SA 10N	6.5	0.7	2.2	2.8	22500	M10x1	20
SA 10SN	6.5	1.8	5.4	2.8	22500	M10x1	20
SA 10S2N	6.5	4.6	13.6	2.8	22500	M10x1	20
SA 12N	10	0.3	1.1	9.0	28200	M12x1	22
SA 12SN	10	0.9	4.8	9.0	28200	M12x1	22
SA 12S2N	10	2.7	36.2	9.0	28200	M12x1	22
SA 14	12.5	0.9	10	17	34000	M14x1.5 ¹⁾	24
SA 14S	12.5	8.6	86	17	34000	M14x1.5 ¹⁾	24
SA 14S2	12.5	68	205	17	34000	M14x1.5 ¹⁾	24
SA 20	12.5	2.3	25	25	45000	M20x1.5	27
SA 20x25	24.6	2.3	16	50.8	68000	M20x1.5	27
SA 20S	12.5	23	230	25	45000	M20x1.5	27
SA 20Sx25	24.6	9	59	50.8	68000	M20x1.5	27
SA 20S2	12.5	182	910	25	45000	M20x1.5	27
SA 20S2x25	24.6	36	227	50.8	68000	M20x1.5	27
SAI 25	25.4	9	136	68	68000	M25x1.5	30
SAI 25S	25.4	113	1130	68	68000	M25x1.5	30
SAI 25S2	25.4	400	2273	68	68000	M25x1.5	30
SA 33x25	25.4	9	40	153	75000	M33x1.5	33
SA 33Sx25	25.4	30	120	153	75000	M33x1.5	33
SA 33S2x25	25.4	100	420	153	75000	M33x1.5	33
SA 33S3x25	25.4	350	1420	153	75000	M33x1.5	33
SA 33x50	50.8	18	70	305	85000	M33x1.5	33
SA 33Sx50	50.8	60	250	305	85000	M33x1.5	33
SA 33S2x50	50.8	210	840	305	85000	M33x1.5	33
SA 33S3x50	50.8	710	2830	305	85000	M33x1.5	33
SA 45x25	25.4	20	90	339	107000	M45x1.5	37
SA 45Sx25	25.4	80	310	339	107000	M45x1.5	37
SA 45S2x25	25.4	260	1050	339	107000	M45x1.5	37
SA 45S3x25	25.4	890	3540	339	107000	M45x1.5	37
SA 45x50	50.8	45	180	678	112000	M45x1.5	37
SA 45Sx50	50.8	150	620	678	112000	M45x1.5	37
SA 45S2x50	50.8	520	2090	678	112000	M45x1.5	37
SA 45S3x50	50.8	1800	7100	678	112000	M45x1.5	37
SA 45x75	76.2	70	270	1017	146000	M45x1.5	37
SA 45Sx75	76.2	230	930	1017	146000	M45x1.5	37

¹⁾Option: M14x1 thread

Non-Adjustable Shock Absorbers

Type	Stroke (mm)	Effective Mass m_e (kg)		Max Energy Absorption (Nm)		Thread Size	Page
		Min.	Max.	per stroke W_3	per hour W_4		
SA 45S2x75	76.2	790	3140	1017	146000	M45x1.5	37
SA 45S3x75	76.2	2650	10600	1017	146000	M45x1.5	37
SA 64x50	50.8	140	540	1695	146000	M64x2	41
SA 64Sx50	50.8	460	1850	1695	146000	M64x2	41
SA 64S2x50	50.8	1600	6300	1695	146000	M64x2	41
SA 64S3x50	50.8	5300	21200	1695	146000	M64x2	41
SA 64x100	101.6	270	1100	3390	192000	M64x2	41
SA 64Sx100	101.6	930	3700	3390	192000	M64x2	41
SA 64S2x100	101.6	3150	12600	3390	192000	M64x2	41
SA 64S3x100	101.6	10600	42500	3390	192000	M64x2	41
SA 64x150	150.1	410	1640	5084	248000	M64x2	41
SA 64Sx150	150.1	1390	5600	5084	248000	M64x2	41
SA 64S2x150	150.1	4700	18800	5084	248000	M64x2	41
SA 64S3x150	150.1	16000	63700	5084	248000	M64x2	41

Overview of Non-Adjustable Shock Absorbers

Adjustable Shock Absorbers

SA 1/4 x 1/2	12.7	1.0	190	20	35000	M20x1.5	44
SA 3/8 x 1D	25.4	4.5	546	70	68000	M25x1.5 ²⁾	46
SALD 1/2 x 1M	25.4	4.5	1360	170	85000	M36x1.5	48
SALD 1/2 x 2M	50.8	9.5	2720	340	98000	M36x1.5	48
SA 1/2 x 1	25.4	4.5	1225	153	84700	M33x1.5	51
SA 1/2 x 2	50.8	9.5	2450	305	98300	M33x1.5	51
SA 3/4 x 1	25.4	9	8163	339	124300	M42x1.5	55
SA 3/4 x 2	50.8	16	14500	678	146800	M42x1.5	55
SA 3/4 x 3	76	23	20866	1017	180776	M42x1.5	55
SA 1-1/8 x 2	50.8	54	22680	1808	169478	M64x2.0	59
SA 1-1/8 x 4	102	73	45360	3616	225970	M64x2.0	59
SA 1-1/8 x 6	152	91	68040	5423	282463	M64x2.0	59
SA-A 3/4 x 1	25.4	27	3600	290	184000 ³⁾	M42x1.5	63
SA-A 3/4 x 2	50.8	43	6350	600	230000 ³⁾	M42x1.5	63
SA-A 3/4 x 3	76	55	9500	890	276000 ³⁾	M42x1.5	63
SA-A 1-1/8 x 2	50.8	72	13000	1380	345000 ³⁾	M64x2.0	67

²⁾Option: M27x3 thread ³⁾Operation with external air-oil tank

Further shock absorber sizes (1-1/2", 2", 2-1/4", 3", 4") in various stroke lengths are also available on request.

Overview of Adjustable Shock Absorbers

Installation Tips

Mounting

ORIGA shock absorbers should generally be mounted on a rigid structure with adequate strength.

The strength required should be calculated by the following formula:

$$\frac{2.5 \cdot W_3 \text{ (max)}}{S}$$

Avoid sideloads of more than 5° and align the centreline of the piston as closely as possible with the centre of gravity of the impacting load (see diagram).

Positive Stops

External positive stops are always required to produce a firm work-positioning and prevent the shock absorber from „bottoming out“. This is achieved either with external dead stops or a stop collar. These are located to stop the piston no more than 1.6 mm short of the end of stroke.

Oil Filling

ORIGA shock absorbers with return springs are supplied prefilled with oil and ready for immediate use without any additional pipework etc..

For shock absorbers without return springs an external accumulator or air/oil tank is required.

The air/oil tank is filled with the correct oil up to the „Full“ mark (do not overfill), then the shock absorber can be operated at low speed while it is being finally adjusted.

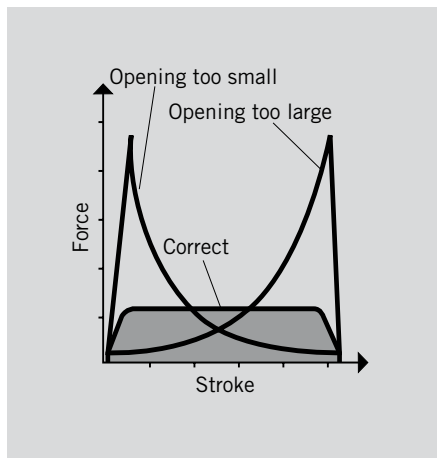

Adjustment

All ORIGA shock absorbers are supplied with their adjustment preset at 90°, which is midway between the „hard“ and „soft“ settings.

To adjust the shock absorber, first loosen the adjustor's lock screw with an Allan key.

Then impact the load slowly on the shock absorber. If the initial impact is too hard, use a screwdriver or coin to rotate the adjustor towards „soft“ (18) on the dial. If the initial impact is too soft, rotate the adjustor in the opposite direction towards „hard“ (0). When the setting is correct, retighten the adjustor's lock screw with the Allan key.

The shock absorber is pro-perly adjusted when there is no initial impact at the start of the stroke and no hard set-down at the end of the stroke.

If hard set-down persists despite proper adjustment, check whether the positive stop is set correctly to keep the shock absorber piston no more than 1.6 mm off the bottom at end of stroke.

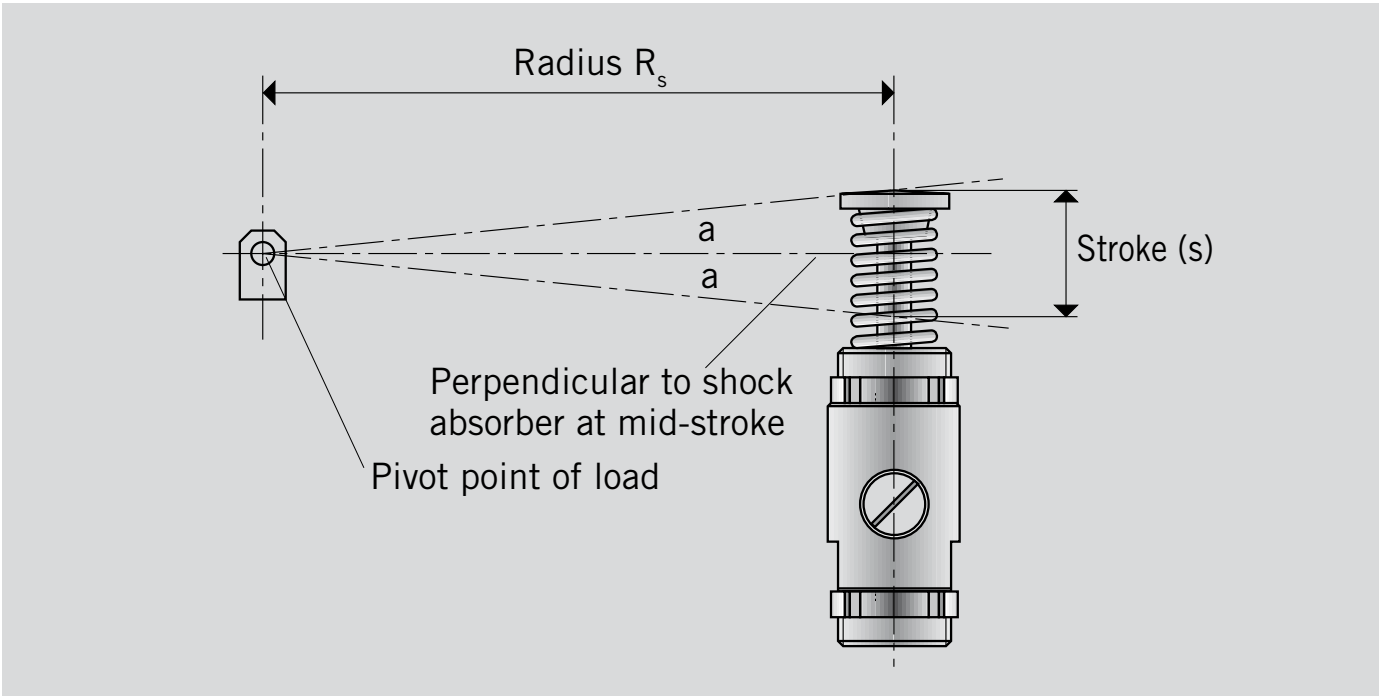

Installation Angle (a)	$\frac{S}{R_s}$	a	$\frac{S}{R_s}$	a
The installation angle (a) is found by dividing the shock absorber stroke (S) by the radius of the shock absorber from the pivot point (R). The installation angle should never exceed 5°. If it does, a shorter stroke or a longer radius must be used.	0.0175	0.5°	0.1051	3.0°
	0.0349	1.0°	0.1228	3.5°
	0.0524	1.5°	0.1405	4.0°
	0.0699	2.0°	0.1584	4.5°
	0.0875	2.5°	0.1763	5.0°

Shock Absorbers

Hydraulic Industrial Shock Absorbers

Type:

- Non-adjustable

Series SA

SA 10N

- For smaller effective masses

SA 10SN

- For intermediate effective masses

SA 10S2N

- For larger effective masses

Basic Version with:

- Integral stop collar
- 1 mounting nut
- Soft pad

Accessories:

- Universal flange

Energy Capacity

Type	Stroke (mm)	Effective Mass (kg)		Max. Energy Capacity (Nm)	
		Min.	Max.	per stroke W_3	per hour W_4
SA 10N	6.5	0.7	2.2	2.8	22500
SA 10SN	6.5	1.8	5.4	2.8	22500
SA 10S2N	6.5	4.6	13.6	2.8	22500

Technical Data

Characteristic	Unit	Comments
Impact velocity	m/s	0.15 - 2.2
Operating temperature range	°C	0 to 65
Installation		In any position
Force of internal return spring	N	3 - 6
Max. deviation of impacting force from centre axis of shock absorber		±2°
Weight (mass)	kg	0.020
Min. mounting strength required	N	1080 ¹⁾
Materials		
Body		Steel, black oxide finish
Piston rod		Steel, hardened, ground, hard-chrome plated
Accessories		Steel, black oxide finish or aluminium, anodized

¹⁾ based on $\frac{2.5 \cdot W_3}{\text{stroke}}$



For product group overview see page 16 + 17
For design and installation notes see from page 4

Dimensions (mm) – Shock Absorbers

Type: SA 10N, SA 10 SN, SA 10 S2N

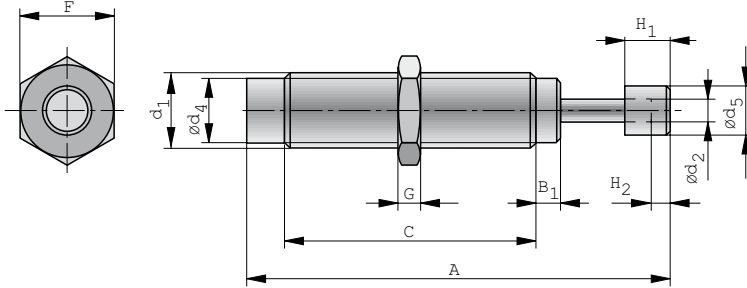

Dimensions (mm) – Universal Flange

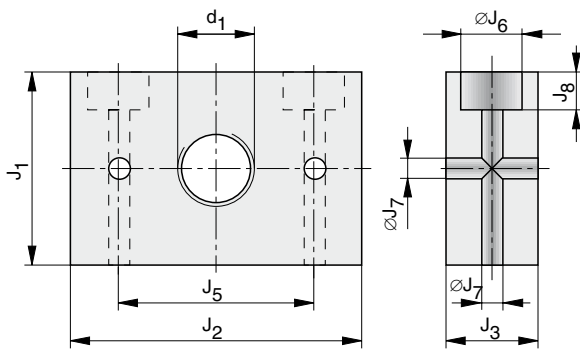

Dimensions Table (mm)

A	B ₁	C	d ₁	ød ₂	ød ₄	ød ₅	F	G	H ₁	H ₂	J ₁	J ₂	J ₃	J ₅	øJ ₆	øJ ₇	J ₈
57.6	5.0	33.0	M10x1	3.2	8.4	7.6	12.0	4	8.0	3.0	25.4	38	12	25.4	8	4.5	5

Order Instructions

Product	Order Instructions	
	Type	Order No.
Shock absorber for smaller effective masses	SA 10N	7717
Shock absorber for intermediate effective masses	SA 10 SN	7718
Shock absorber for larger effective masses	SA 10 S2N	7721
Additional mounting nut	LN 10	7909
Universal flange	UM 10	7902

Shock Absorbers

Hydraulic Industrial Shock Absorbers

Type:

- Non-adjustable

Series SA

SA 12N

- For smaller effective masses

SA 12SN

- For intermediate effective masses

SA 12S2N

- For larger effective masses

Basic Version with:

- Integral stop collar
- 1 mounting nut
- Soft pad

Accessories:

- Universal flange

Energy Capacity

Type	Stroke (mm)	Effective Mass (kg)		Max. Energy Capacity (Nm)	
		Min.	Max.	per stroke W_3	per hour W_4
SA 12N	10	0.3	1.1	9.0	28200
SA 12SN	10	0.9	4.8	9.0	28200
SA 12S2N	10	2.7	36.2	9.0	28200

Technical Data

Characteristic	Unit	Comments
Impact velocity	m/s	0.15 - 5
Operating temperature range	°C	0 to 65
Installation		In any position
Force of internal return spring	N	4 - 9
Max. deviation of impacting force from centre axis of shock absorber		±2°
Weight (mass)	kg	0.030
Min. mounting strength required	N	2250 ¹⁾
Materials		
Body		Steel, black oxide finish
Piston rod		Steel, hardened, ground, hard-chrome plated
Accessories		Steel, black oxide finish or aluminium, anodized

¹⁾ based on $\frac{2.5 \cdot W_3}{\text{stroke}}$



For product group overview see page 16 + 17
For design and installation notes see from page 4

Dimensions (mm) – Shock Absorbers

Type: SA 12N, SA 12 SN, SA 12 S2N

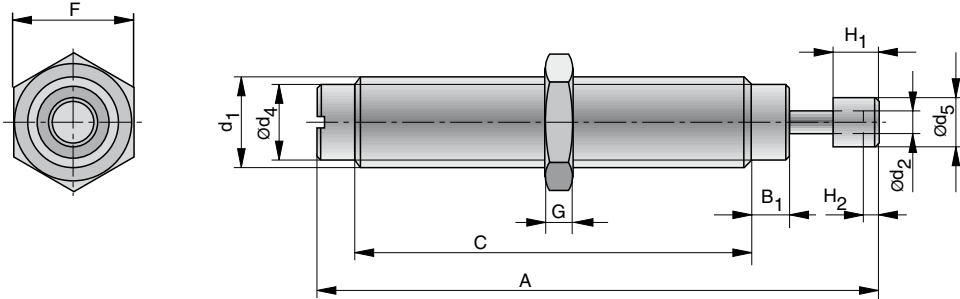

Dimensions (mm) – Universal Flange

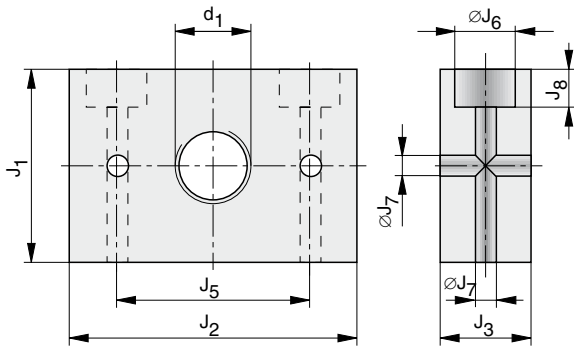

Dimensions Table (mm)

A	B	B ₁	C	d ₁	ød ₂	ød ₄	ød ₅	F	G	H ₁	H ₂	J ₁	J ₂	J ₃	J ₅	øJ ₆	øJ ₇	J ₈
67	10	3.0	44	M12x1	3.2	10.4	7.6	14	5	8	3	25.4	38	12	25.4	8	4.5	5

Order Instructions

Product	Order Instructions	
	Type	Order No.
Shock absorber for smaller effective masses	SA 12N	7719
Shock absorber for intermediate effective masses	SA 12 SN	7722
Shock absorber for larger effective masses	SA 12 S2N	7723
Additional mounting nut	LN 12	7919
Universal flange	UM 12	7912

Shock Absorbers

Hydraulic Industrial Shock Absorbers

Type:

- Non-adjustable

Series SA

SA 14

- For smaller effective masses

SA 14 S

- For intermediate effective masses

SA 14 S2

- For larger effective masses

Basic Version with:

- Integral stop collar
- 1 mounting nut

Accessories:

- Soft pad
- Universal Flange

Energy Capacity

Type	Stroke (mm)	Effective Mass (kg)		Max. Energy Capacity (Nm)	
		Min.	Max.	per stroke W_3	per hour W_4
SA 14	12.5	0.9	10	17	34000
SA 14S	12.5	8.6	86	17	34000
SA 14S2	12.5	68	205	17	34000

Technical Data

Characteristic	Unit	Comments
Impact velocity	m/s	0.3 - 4.5
Operating temperature range	°C	0 to 65
Installation		In any position
Force of internal return spring	N	4 - 7
Max. deviation of impacting force from centre axis of shock absorber		±3°
Weight (mass)	kg	0.125
Min. mounting strength required	N	3400 ¹⁾
Materials		
Body		Steel, black oxide finish
Piston rod		Steel, hardened, ground, hard-chrome plated
Accessories		Steel, black oxide finish or aluminium, anodized

¹⁾ based on $\frac{2.5 \cdot W_3}{\text{stroke}}$



For product group overview see page 16 + 17
For design and installation notes see from page 4

Dimensions (mm) – Shock Absorbers

Type: SA 14, SA 14 S, SA 14 S2

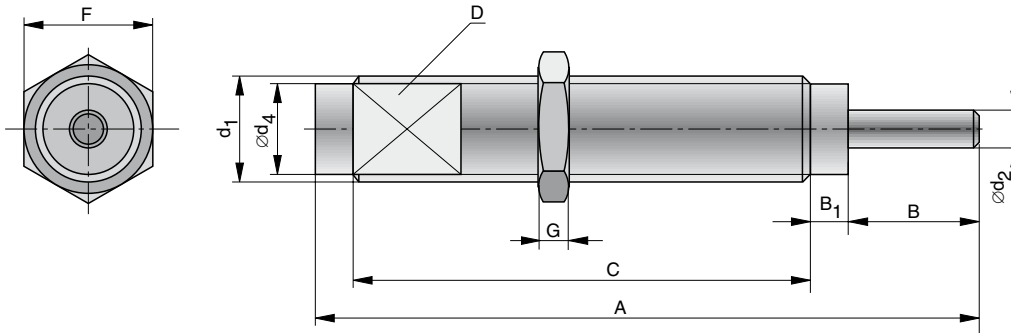

Dimensions (mm) – Universal Flange

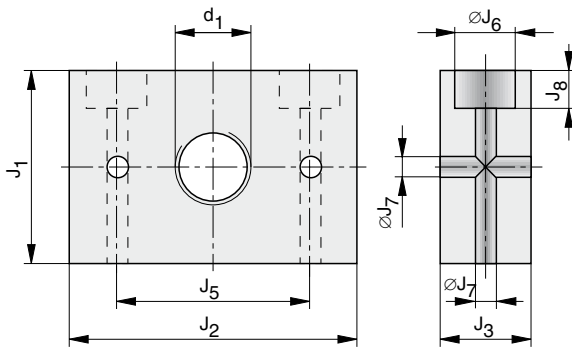

Dimensions (mm) – Soft Pad

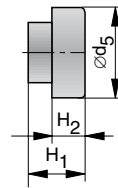

Dimensions Table (mm)

A	B	B ₁	C	D	d ₁	ød ₂	ød ₄	ød ₅	F	G	H ₁	H ₂	J ₁	J ₂	J ₃	J ₅	øJ ₆	øJ ₇	J ₈
87	12	4	61	12	M14x1.5 ¹⁾	4.8	12	11.9	17	5	10.9	6.9	29	45	16	35	8	4.5	5

¹⁾ Option: M14x1 thread (d₁)

Order Instructions

Product	Order Instructions	
	Type	Order No.
Shock absorber for smaller effective masses	SA 14	7920
Shock absorber for intermediate effective masses	SA 14 S	7927
Shock absorber for larger effective masses	SA 14 S2	7928
Soft pad	SP 14	7924
Additional mounting nut	LN 14	7929
Universal flange	UM 14	7922

Energy Capacity

Type	Stroke (mm)	Effective Mass (kg)		Max. Energy Capacity (Nm)	
		Min.	Max.	per stroke W_3	per hour W_4
SA 20	12.5	2.3	25	25	45000
SA 20S	12.5	23	230	25	45000
SA 20S2	12.5	182	910	25	45000
SA 20x25	24.6	2.3	16	50.8	68000
SA 20Sx25	24.6	9	59	50.8	68000
SA 20S2x25	24.6	36	227	50.8	68000

Technical Data

Characteristic	Unit	Comments
Impact velocity	m/s	0.3 - 4.5
Operating temperature range	°C	0 to 65
Installation		in any position
Force of internal return spring	N	6 - 10
Max. deviation of impacting force from centre axis of shock absorber		±3°
Weight (mass)	kg	0.176 (Type SA20), 0.207 (Type SA20x25)
Min. mounting strength required	N	5000 ¹⁾
Materials		
Body		Steel, black oxide finish
Piston rod		Steel, hardened, ground, hard-chrome plated
Accessories		Steel, black oxide finish or aluminium, anodized

¹⁾ based on $\frac{2.5 \cdot W_3}{\text{stroke}}$

Shock Absorbers

Hydraulic Industrial Shock Absorbers

Type:

- Non-adjustable

Series SA

- **SA 20**
Stroke 12.5 mm
- **SA 20x25**
Stroke 24.6 mm
For smaller effective masses
- **SA 20S**
Stroke 12.5 mm
- **SA 20Sx25**
Stroke 24.6 mm
For intermediate effective masses
- **SA 20S2**
Stroke 12.5 mm
- **SA 20S2x25**
Stroke 24.6 mm
For larger effective masses

Basic Version with:

- Integral stop collar
- 1 mounting nut

Accessories:

- Soft pad
- Universal flange



For product group overview see page 16 + 17
For design and installation notes see from page 4

Dimensions (mm) – Shock Absorbers

Typ: SA 20, SA 20 S, SA 20 S2

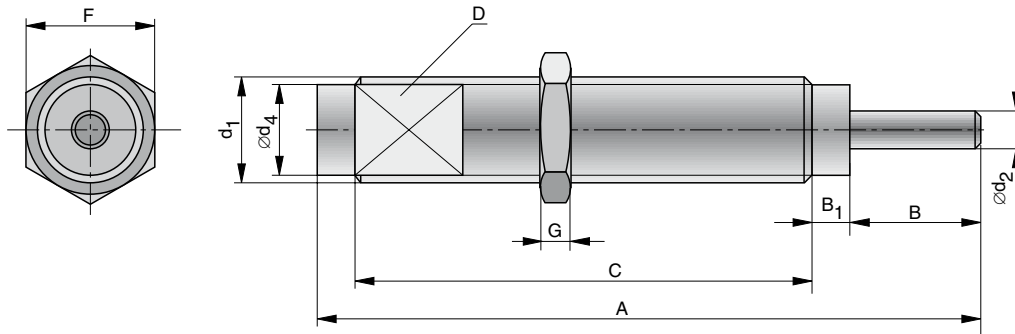

Dimensions (mm) – Universal Flange

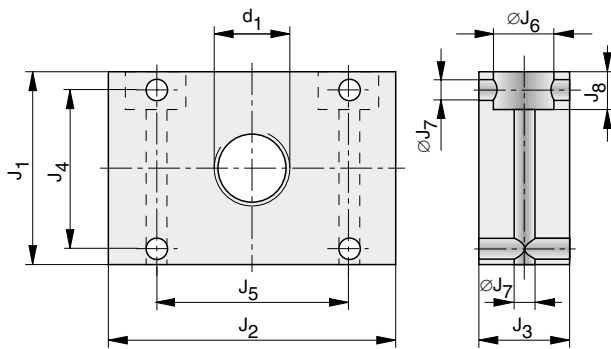

Dimensions (mm) – Soft Pad

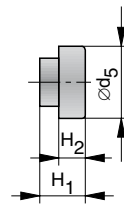

Dimensions Table (mm)

Type	A	B	B ₁	C	D	d ₁	$\varnothing d_2$	$\varnothing d_4$	$\varnothing d_5$	F
SA 20	89	12	5.6	61.7	17	M20x1.5	6.4	17	17	23.9
SA 20x25	140.5	24.6	5.6	100.3	17	M20x1.5	6.4	17	17	25.4

Type	G	H ₁	H ₂	J ₁	J ₂	J ₃	J ₄	J ₅	$\varnothing J_6$	$\varnothing J_7$	J ₈
SA 20	6	10.7	4.7	35	46	16	25.4	35	10.4	5.5	10.4
SA 20x25	6	10.7	4.7	35	46	16	25.4	35	10.4	5.5	10.4

Order instructions

Product	Order Instructions		
	Type	Order No.	
Shock absorber for smaller effective masses	– stroke 12.5 mm	SA 20	7930
	– stroke 24.6 mm	SA 20x25	7700
Shock absorber for intermediate effective masses	– stroke 12.5 mm	SA 20 S	7937
	– stroke 24.6 mm	SA 20 Sx25	7701
Shock absorber for larger effective masses	– stroke 12.5 mm	SA 20 S2	7938
	– stroke 24.6 mm	SA 20 S2x25	7702
Soft pad	SP 20	7934	
Additional mounting nut	LN 20	7939	
Universal flange	UM 20	7932	

Shock Absorbers

Hydraulic Industrial Shock Absorbers

Type:

- Non-adjustable

Series SAI

SAI 25

- For smaller effective masses

SAI 25 S

- For intermediate effective masses

SAI 25 S2

- For larger effective masses

Basic Version with:

- Integral stop collar
- 1 mounting nut

Accessories:

- Soft pad
- Universal flange

Energy Capacity

Type	Stroke (mm)	Effective Mass (kg)		Max. Energy Capacity (Nm)	
		Min.	Max.	per stroke W_3	per hour W_4
SAI 25	25.4	9	136	68	68000
SAI 25S	25.4	113	1130	68	68000
SAI 25S2	25.4	400	2273	68	68000

Technical Data

Characteristic	Unit	Comments
Impact velocity	m/s	0.3 - 4.5
Operating temperature range	°C	0 to 65
Installation		in any position
Force of internal return spring	N	19 - 37
Max. deviation of impacting force from centre axis of shock absorber		±3°
Weight (mass)	kg	0.327
Min. mounting strength required	N	6700 ¹⁾
Materials		
Body		Steel, black oxide finish
Piston rod		Steel, hardened, ground, hard-chrome plated
Accessories		Steel, black oxide finish or aluminium, anodized

¹⁾ based on $\frac{2.5 \cdot W_3}{\text{stroke}}$



For product group overview see page 16 + 17
For design and installation notes see from page 4

Dimensions (mm) – Shock Absorbers

Type: SAI 25, SAI 25 S, SAI 25 S2

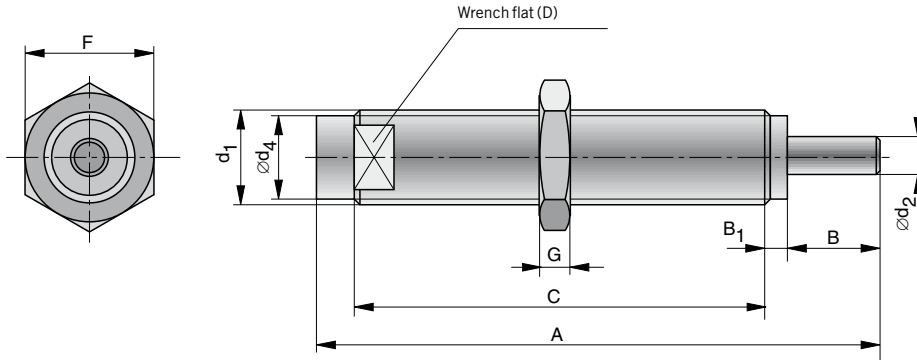

Dimensions (mm) – Universal Flange

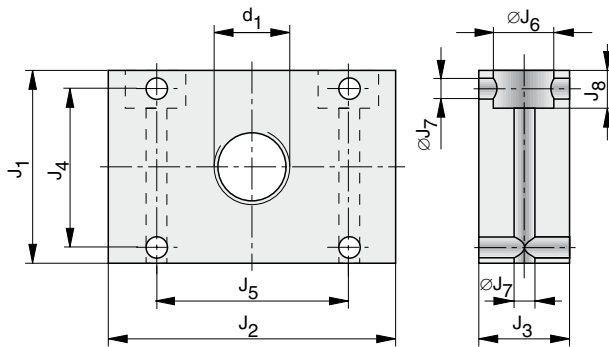

Dimensions (mm) – Soft Pad

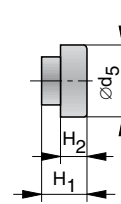

Dimensions Table (mm)

A	B	B ₁	C	D	d ₁ *	ød ₂	ød ₄	ød ₅	F	G	H ₁	H ₂	J ₁	J ₂	J ₃	J ₄	J ₅	øJ ₆	øJ ₇	J ₈
149.1	24.6	4.6	107.2	22	M25x1.5	7.9	22.4	22.3	30	8	11	4.7	35	47	16	25.5	35	10.4	5.5	10.4

* Option M27x3 on request

Order Instructions

Product	Order Instructions	
	Type	Order No.
Shock absorber for smaller effective masses	SAI 25	7834
Shock absorber for intermediate effective masses	SAI 25 S	7835
Shock absorber for larger effective masses	SAI 25 S2	7836
Soft pad	SP-25	7837
Additional mounting nut	LN-25	7959
Universal flange	UM-25	7952

Energy Capacity

Type	Stroke (mm)	Effective Mass (kg)		Max. Energy Capacity (Nm)	
		Min.	Max.	per stroke W_3	per hour W_4
SA 33x25	25.4	9	40	153	75000
SA 33Sx25	25.4	30	120	153	75000
SA 33S2x25	25.4	100	420	153	75000
SA 33S3x25	25.4	350	1420	153	75000
SA 33x50	50.8	18	70	305	85000
SA 33Sx50	50.8	60	250	305	85000
SA 33S2x50	50.8	210	840	305	85000
SA 33S3x50	50.8	710	2830	305	85000

Technical Data

Characteristic	Unit	Comments
Impact velocity	m/s	0.15 to 5
Operating temperature range	°C	-12 to +70
Installation		in any position
Force of internal return spring	N	on request
Max. deviation of impacting force from centre axis of shock absorber		Type SA33...-25 – 4° Type SA33...-50 – 3°
Weight (mass)	kg	Type SA33...-25 – 0.45 Type SA33...-50 – 0.54
Min. mounting strength required	N	on request ¹⁾
Materials		
Body		Steel, black oxide finish
Piston rod		Steel, hardened, ground, hard-chrome plated
Accessories		Steel, black oxide finish or aluminium, anodized

¹⁾ based on $\frac{2.5 \cdot W_3}{\text{stroke}}$

Shock Absorbers

Hydraulic Industrial Shock Absorbers

Type:

- Non-adjustable

Series SA

- **SA 33x25**
Stroke 25.4 mm
- **SA 33x50**
Stroke 50.8 mm
For smaller effective masses
- **SA 33Sx25**
Stroke 25.4 mm
- **SA 33Sx50**
Stroke 50.8 mm
For intermediate effective masses
- **SA 33S2x25**
Stroke 25.4 mm
- **SA 33S2x50**
Stroke 50.8 mm
For larger effective masses
- **SA 33S3x25**
Stroke 25.4 mm
- **SA 33S3x50**
Stroke 50.8 mm
For high effective masses

Basic Version with:

- 1 mounting nut

Accessories:

- Soft pad
- Rectangular flange
- Foot mounting
- Stop collar



For product group overview see page 16 + 17
For design and installation notes see from page 4

Dimensions (mm) – Shock Absorbers

Type: SA 33..x25, SA 33..x50

Mounting nut

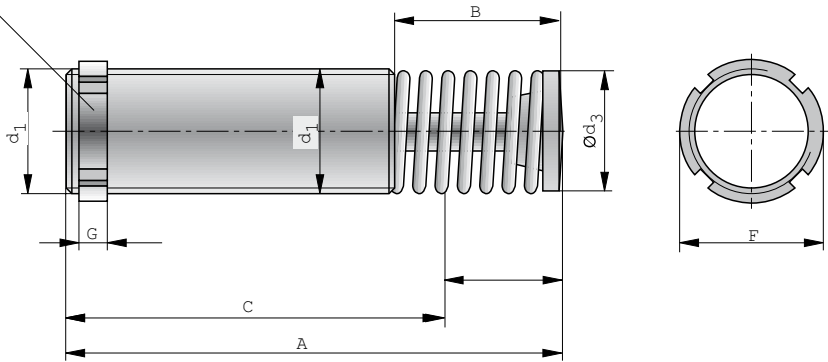

**Dimensions (mm)
Soft Pad**

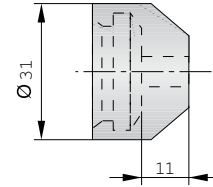

Note:
Cannot be used with stop collar.

Dimensions (mm) – Rectangular Flange

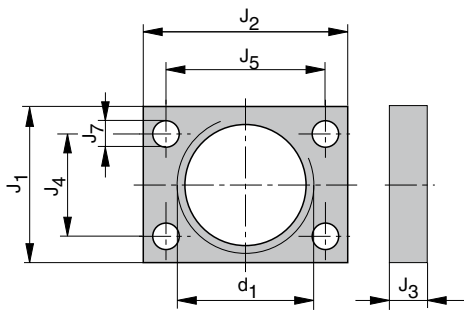

Dimensions (mm) – Stop Collar

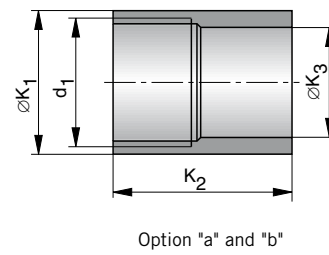

Option "a" and "b"

Option "a" - for rear mounting
Option "b" - for front mounting

Dimensions (mm) – Foot Mounting

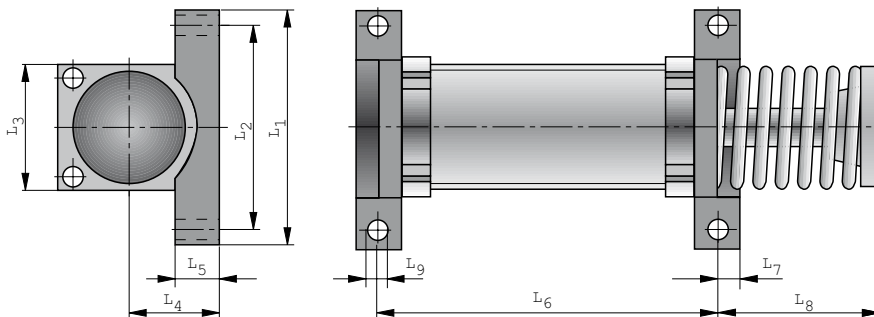

Dimensions Table (mm)

Type	Stroke	A	B	C	d ₁	Ød ₃	ØF	G	Ød ₅	H ₁	H ₂	J ₁
SA 33..x25	25.4	138	55	83	M33x1.5	25	39.6	6.5	31.8	19.1	11.2	38.1
SA 33..x50	50.8	189	81	108	M33x1.5	25	39.6	6.5	31.8	19.1	11.2	38.1

Type	J ₂	J ₃	J ₄	J ₅	ØK ₁	K _{2,a}	K _{2,b}	ØK ₃	L ₁	L ₂	L ₃	L ₄	L ₅	L ₆	L ₇	L ₈	L ₉
SA 33..x25	50,8	9,7	28,7	41,4	38,1	47,6	41,3	28,6	69,9	60,3	50,8	22,2	12,7	95,3	6,4	49,2	5,6
SA 33..x50	50,8	9,7	28,7	41,4	38,1	47,6	41,3	28,6	69,9	60,3	50,8	22,2	12,7	121	6,4	74,6	5,6

Order Instructions

Product	Order Instructions		
	Type	Order No.	
Shock absorber for smaller effective masses	– Stroke 25.4 mm	SA 33x25	8041
	– Stroke 50.8 mm	SA 33x50	8045
Shock absorber for intermediate masses	– Stroke 25.4 mm	SA 33Sx25	8042
	– Stroke 50.8 mm	SA 33Sx50	8046
Shock absorber for larger masses	– Stroke 25.4 mm	SA 33S2x25	8043
	– Stroke 50.8 mm	SA 33S2x50	8047
Shock absorber for high masses	– Stroke 25.4 mm	SA 33S3x25	8044
	– Stroke 50.8 mm	SA 33S3x50	8048
Stop collar Option "a"	for rear mounting	SC1/2A	7971
Stop collar Option "b"	for front mounting	SC1/2B	7977
Soft pad		SP1/2	7974
Additional mounting nut		LN1/2	7979
Rectangular flange		RF1/2	7972
Foot mounting		FM1/2	7973

Energy Capacity

Type	Stroke (mm)	Effective Mass (kg)		Max. Energy Capacity (Nm)	
		Min.	Max.	per stroke W_3	per hour W_4
SA 45x25	25.4	20	90	339	107000
SA 45Sx25	25.4	80	310	339	107000
SA 45S2x25	25.4	260	1050	339	107000
SA 45S3x25	25.4	890	3540	339	107000
SA 45x50	50.8	45	180	678	112000
SA 45Sx50	50.8	150	620	678	112000
SA 45S2x50	50.8	520	2090	678	112000
SA 45S3x50	50.8	1800	7100	678	112000
SA 45x75	76.2	70	270	1017	146000
SA 45Sx75	76.2	230	930	1017	146000
SA 45S2x75	76.2	790	3140	1017	146000
SA 45S3x75	76.2	2650	10600	1017	146000

Technical Data

Characteristic	Unit	Comments
Impact velocity	m/s	0.15 to 5
Operating temperature range	°C	-12 to +70°
Installation		in any position
Force of internal return spring	N	on request
Max. deviation of impacting force from centre axis of shock absorber		Type SA45...-25 – 4° Type SA45...-50 – 3° Type SA45...-75 – 2°
Weight (mass)	kg	Type SA45...-25 – 1,13 Type SA45...-50 – 1,36 Type SA45...-75 – 1,59
Min. mounting strength required	N	on request ¹⁾
Materials		
Body		Steel, black oxide finish
Piston rod		Steel, hardened, ground, hard-chrome plated
Accessories		Steel, black oxide finish or aluminium, anodized

¹⁾ based on $\frac{2.5 \cdot W_3}{\text{stroke}}$

Shock Absorbers

Hydraulic Industrial Shock Absorbers

Type:

- Non-adjustable

Series SA

- **SA 45x25**
Stroke 25.4 mm
- **SA 45x50**
Stroke 50.8 mm
- **SA 45x75**
Stroke 76.2 mm
For smaller effective masses
- **SA 45Sx25**
Stroke 25.4 mm
- **SA 45Sx50**
Stroke 50.8 mm
- **SA 45Sx75**
Stroke 76.2 mm
For intermediate effective masses
- **SA 45S2x25**
Stroke 25.4 mm
- **SA 45S2x50**
Stroke 50.8 mm
- **SA 45S2x75**
Stroke 76.2 mm
For higher effective masses
- **SA 45S3x25**
Stroke 25.4 mm
- **SA 45S3x50**
Stroke 50.8 mm
- **SA 45S3x75**
Stroke 76.2 mm
For high effective masses

Basic Version with:

- 1 Mounting nut

Accessories:

- Soft pad
- Rectangular flange
- Foot mounting
- Stop collar



For product group overview see page 16 + 17
For design and installation notes see from page 4

Dimensions (mm) – Shock Absorbers

Type: SA 45..x25, SA 45..x50, SA45..x75

Mounting nut

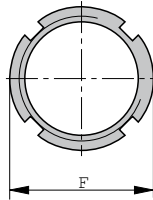
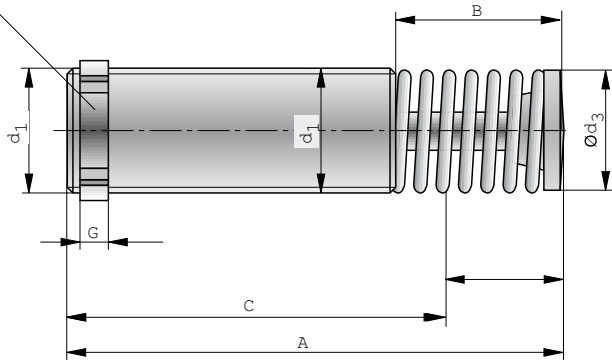

**Dimensions (mm)
Soft Pad**

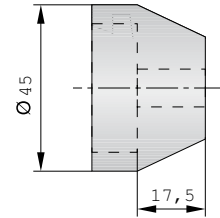

Note:
Cannot be used with stop collar.

Dimensions (mm) – Rectangular Flange

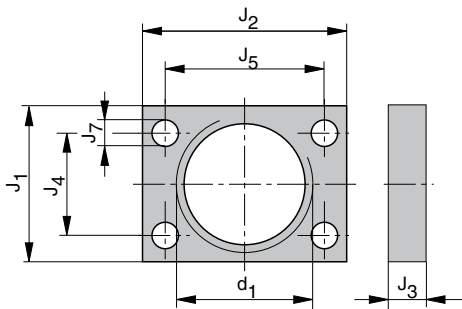

Dimensions (mm) – Stop Collar

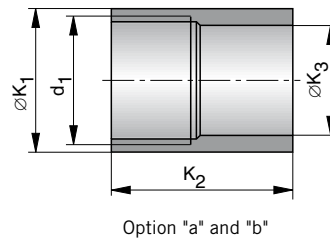

Option "a" and "b"

Option "a" - for rear mounting
Option "b" - for front mounting

Dimensions (mm) – Foot Mounting

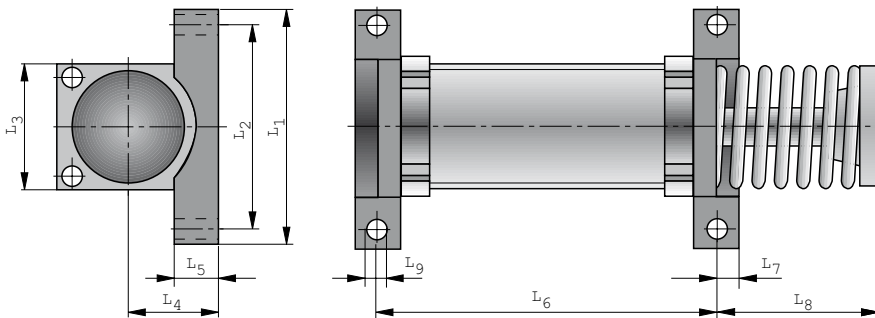

Dimensions Table (mm)

Type	Hub	A	B	C	d ₁	Ød ₃	ØF	G	Ød ₅	H ₁	H ₂	J ₁
SA 45..x25	25.4	145	50	95	M45x1.5	35	55.6	9.5	44.5	25.4	17.5	57.2
SA 45..x50	50.8	195	75	120	M45x1.5	35	55.6	9.5	44.5	25.4	17.5	57.2
SA 45..x75	76.2	246	101	145	M45x1.5	35	55.6	9.5	44.5	25.4	17.5	57.2

Type	J ₂	J ₃	J ₄	J ₅	ØK ₁	K ₂ a	K ₂ b	ØK ₃	L ₁	L ₂	L ₃	L ₄	L ₅	L ₆	L ₇	L ₈	L ₉
SA 45..x25	76.2	12.7	41.4	60.5	on request				95.3	72.2	57.2	29.4	14.2	85.5	9.5	52.3	8.7
SA 45..x50	76.2	12.7	41.4	60.5	on request				95.3	72.2	57.2	29.4	14.2	111	9.5	77.7	8.7
SA 45..x75	76.2	12.7	41.4	60.5	on request				95.3	72.2	57.2	29.4	14.2	111	9.5	103	8.7

Order Instructions

Product	Order Instructions		
	Type	Order No.	
Shock absorber for smaller effective masses	– Stroke 25.4 mm	SA 45x25	8049
	– Stroke 50.8 mm	SA 45x50	8053
	– Stroke 76.2 mm	SA 45x75	8057
Shock absorber for intermediate masses	– Stroke 25.4 mm	SA 45Sx25	8050
	– Stroke 50.8 mm	SA 45Sx50	8054
	– Stroke 76.2 mm	SA 45Sx75	8058
Shock absorber for larger masses	– Stroke 25.4 mm	SA 45S2x25	8051
	– Stroke 50.8 mm	SA 45S2x50	8055
	– Stroke 76.2 mm	SA 45S2x75	8059
Shock absorber for high masses	– Stroke 25.4 mm	SA 45S3x25	8052
	– Stroke 50.8 mm	SA 45S3x50	8056
	– Stroke 76.2 mm	SA 45S3x75	8060
Stop collar	SC ...	on request	
	SC ...	on request	
Soft pad	SP..	on request	
Additional mounting nut	LN..	on request	
Rectangular flange	RF..	on request	
Foot mounting	FM..	on request	

Energy Capacity

Type	Stroke (mm)	Effective Mass (kg)		Max. Energy Capacity (Nm)	
		Min.	Max.	per stroke W_3	per hour W_4
SA 64x50	50.8	140	540	1695	146000
SA 64Sx50	50.8	460	1850	1695	146000
SA 64S2x50	50.8	1600	6300	1695	146000
SA 64S3x50	50.8	5300	21200	1695	146000
SA 64x100	101.6	270	1100	3390	192000
SA 64Sx100	101.6	930	3700	3390	192000
SA 64S2x100	101.6	3150	12600	3390	192000
SA 64S3x100	101.6	10600	42500	3390	192000
SA 64x150	150.1	410	1640	5084	248000
SA 64Sx150	150.1	1390	5600	5084	248000
SA 64S2x150	150.1	4700	18800	5084	248000
SA 64S3x150	150.1	16000	63700	5084	248000

Technical Data

Characteristic	Unit	Comments
Impact velocity	m/s	0.15 to 5
Operating temperature range	°C	-12 to +70
Installation		in any position
Force of internal return spring	N	on request
Max. deviation of impacting force from centre axis of shock absorber		Type SA64...-50 – 4° Type SA64...-100 – 3° Type SA64...-150 – 2°
Weight (mass)	kg	Type SA64...-50 – 2.90 Type SA64...-100 – 3.70 Type SA64...-150 – 5.10
Min. mounting strength required	N	on request ¹⁾
Materials		
Body		Steel, black oxide finish
Piston rod		Steel, hardened, ground, hard-chrome plated
Accessories		Steel, black oxide finish or aluminium, anodized

¹⁾ based on $\frac{2.5 \cdot W_3}{\text{stroke}}$

Shock Absorbers

Hydraulic Industrial Shock Absorbers

Type:

- non-adjustable

Series SA

- **SA 64x50** – Stroke 50.8 mm
SA 64x100 – Stroke 101.6 mm
SA 64x150 – Stroke 150.1 mm
For smaller effective masses
- **SA 64Sx50** – Stroke 50.8 mm
SA 64Sx100 – Stroke 101.6 mm
SA 64Sx150 – Stroke 150.1 mm
For intermediate effective masses
- **SA 64S2x50** – Stroke 50.8 mm
SA 64S2x100 – Stroke 101.6 mm
SA 64S2x150 – Stroke 150.1 mm
For larger effective masses
- **SA 64S3x50** – Stroke 50.8 mm
SA 64S3x100 – Stroke 101.6 mm
SA 64S3x150 – Stroke 150.1 mm
For high effective masses

Basic Version with:

- 1 mounting nut

Accessories:

- Soft pad
- Square flange
- Foot mounting
- Stop collars



For product group overview see page 16 + 17
For design and installation notes see from page 4

Dimensions (mm) – Shock Absorbers

Type: SA 64..x50, SA 64..x100, SA 64..x150

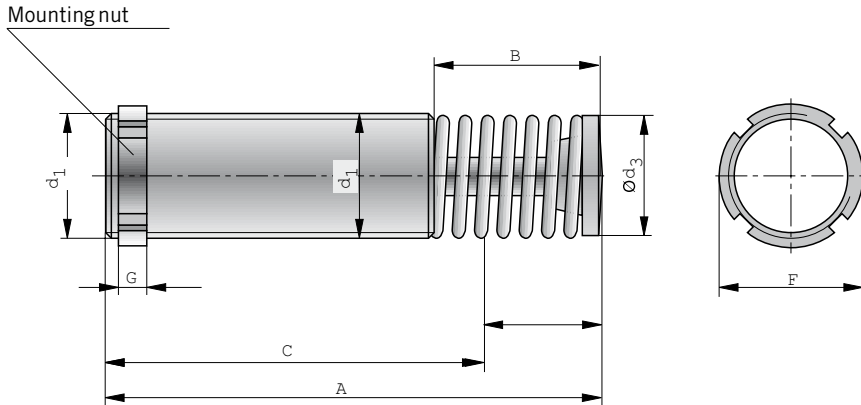

Dimensions (mm) – Soft Pad

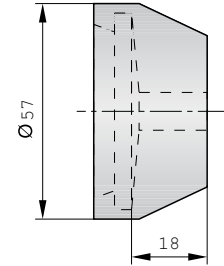

Note:
Cannot be used with stop collar.

Dimensions (mm) – Square Flange

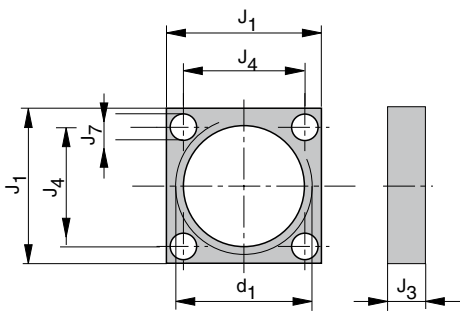

Dimensions (mm) – Stop Collar

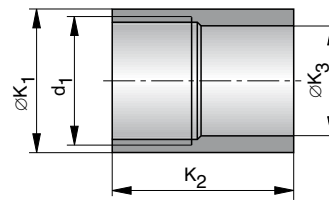

Option "a" and "b"

Option "a" - for rear mounting
Option "b" - for front mounting

Dimensions (mm) – Foot Mounting

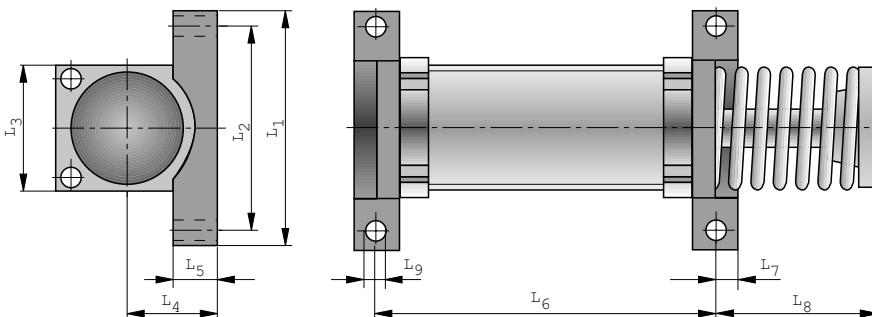

Dimensions Table (mm)

Type	Stroke	A	B	C	d ₁	Ød ₃	ØF	G	Ød ₅	H ₁	H ₂	J ₁
SA 64..x50	50.8	225	85	140	M64x2	48	76	9.5	57.2	25.4	17.5	88.9
SA 64..x100	101.6	326	135	191	M64x2	48	76	9.5	57.2	25.4	17.5	88.9
SA 64..x150	150.1	450	209	241	M64x2	48	76	9.5	57.2	25.4	17.5	88.9

Type	J ₃	J ₄	ØK ₁	K _{2a}	K _{2b}	ØK ₃	L ₁	L ₂	L ₃	L ₄	L ₅	L ₆	L ₇	L ₈	L ₉
SA 64..x50	16	69.9	76.2	62.7	50	60.3	143	124	88.9	44.5	19.1	127	14.2	90	10.3
SA 64..x100	16	69.9	76.2	62.7	50	60.3	143	124	88.9	44.5	19.1	178	14.2	141	10.3
SA 64..x150	16	69.9	76.2	62.7	50	60.3	143	124	88.9	44.5	19.1	229	14.2	214	10.3

Order Instructions

Product	Order Instructions		
	Type	Order No.	
Shock absorber for smaller effective masses	– stroke 50.8 mm	SA 64x50	8061
	– stroke 101.6 mm	SA 64x100	8065
	– stroke 152.4 mm	SA 64x150	8069
Shock absorber for intermediate masses	– stroke 50.8 mm	SA 64Sx50	8062
	– stroke 101.6 mm	SA 64Sx100	8066
	– stroke 152.4 mm	SA 64Sx150	8070
Shock absorber for larger masses	– stroke 50.8 mm	SA 64S2x50	8063
	– stroke 101.6 mm	SA 64S2x100	8067
	– stroke 152.4 mm	SA 64S2x150	8071
Shock absorber for high masses	– stroke 50.8 mm	SA 64S3x50	8064
	– stroke 101.6 mm	SA 64S3x100	8068
	– stroke 152.4 mm	SA 64S3x150	8072
Stop collar Option "a"	for rear mounting	SC 1-1/8A	7991
for Type SA 64..x50 and SA 64..x100			
Stop collar Option "a"	for rear mounting	SC 1-1/8A	7891
for Type SA 64..x150			
Stop collar Option "b"	for front mounting	SC 1-1/8B	7997
for Type SA 64..x50 and SA 64..x100			
Stop collar Option "b"	for front mounting	SC 1-1/8B	7897
for Type SA 64..x150			
Soft pad		SP 1-1/8	7994
Additional mounting nut		LN 1-1/8	7999
Square flange		SF 1-1/8	7998
Foot mounting		FM 1-1/8	7993

Shock Absorbers

Hydraulic Industrial Shock Absorbers

Type:

- Adjustable

Series SA SA 1/4 x 1/2N

Basic Version with:

- Integral stop collar
- 1 mounting nut

Accessories:

- Soft pad
- Universal flange

Energy Capacity

Type	Stroke (mm)	Effective Mass (kg)		Max. Energy Capacity (Nm)	
		Min.	Max.	per stroke W ₃	per hour W ₄
SA 1/4 x 1/2N	12.7	1	190	20	35000

Technical Data

Characteristic	Unit	Comments
Impact velocity	m/s	0.3 - 3.6
Operating temperature range	°C	0 to 65
Installation		in any position
Force of internal return spring	N	3 - 5
Max. deviation of impacting force from centre axis of shock absorber		±3°
Weight (mass)	kg	0.176
Min. mounting strength required	N	3900 ¹⁾
Materials		
Body		Steel, black oxide finish
Piston rod		Steel, hardened, ground, hard-chrome plated
Accessories		Steel, black oxide finish or aluminium, anodized

¹⁾ based on $\frac{2.5 \cdot W_3}{\text{stroke}}$



For product group overview see page 16 + 17
For design and installation notes see from page 4

Dimensions (mm) – Shock Absorbers

Type: SA 1/4 x 1/2

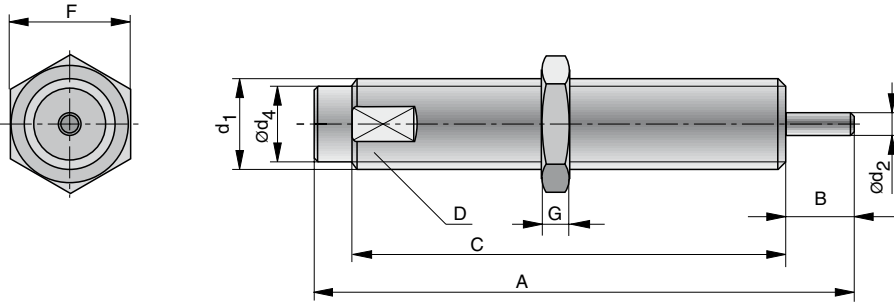

Dimensions (mm) – Universal Flange

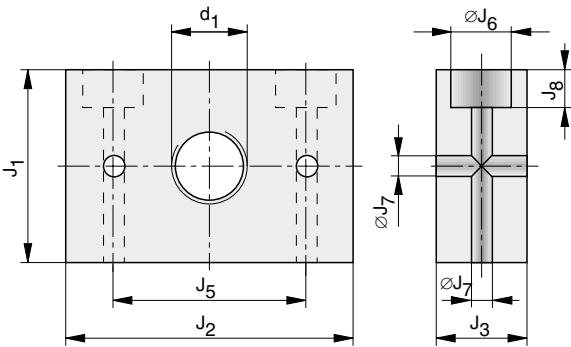

Dimensions (mm) – Soft Pad

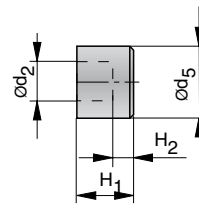

Dimensions Table (mm)

A	B	C	D	d ₁	ød ₂	ød ₄	ød ₅	F	G	H ₁	H ₂	J ₁	J ₂	J ₃	J ₄	J ₅	øJ ₆	øJ ₇	J ₈
86.7	17.7	62	17	M20x1.5	4.8	16.2	12	23	8	9.4	6	35	47	16	25.5	35	10	5.5	10

Order Instructions

Product	Order Instructions	
	Type	Order No.
Shock absorber	SA 1/4 x 1/2N	7720
Additional mounting nut	LN 20	7939
Universal flange	UM 20	7932
Soft pad	SP 1/4 x 1/2N	7724

Shock Absorbers

Hydraulic Industrial Shock Absorbers

Type:

- Adjustable

Series SA SA 3/8 x 1D

Basic Version with:

- 1 mounting nut
- Front and rear adjustment

Accessories:

- Stop collar
- Soft pad
- Universal flange

Energy Capacity

Type	Stroke (mm)	Effective Mass (kg)		Max. Energy Capacity (Nm)	
		Min.	Max.	per stroke W_3	per hour W_4
SA 3/8 x 1D	25.4	4.5	546	70	68000

Technical Data

Characteristic	Unit	Comments
Impact velocity	m/s	0.3 - 4.5
Operating temperature range	°C	-12 to 65
Installation		in any position
Force of internal return spring	N	19 - 37
Max. deviation of impacting force from centre axis of shock absorber		±3°
Weight (mass)	kg	0.243
Min. mounting strength required	N	6900 ¹⁾
Materials		
Body		Steel, black oxide finish
Piston rod		Steel, hardened, ground, hard-chrome plated
Accessories		Steel, black oxide finish or aluminium, anodized

¹⁾ based on $\frac{2.5 \cdot W_3}{\text{stroke}}$



For product group overview see page 16 + 17
For design and installation notes see from page 4

Dimensions (mm) – Shock Absorbers

Type: SA 3/8 x 1D

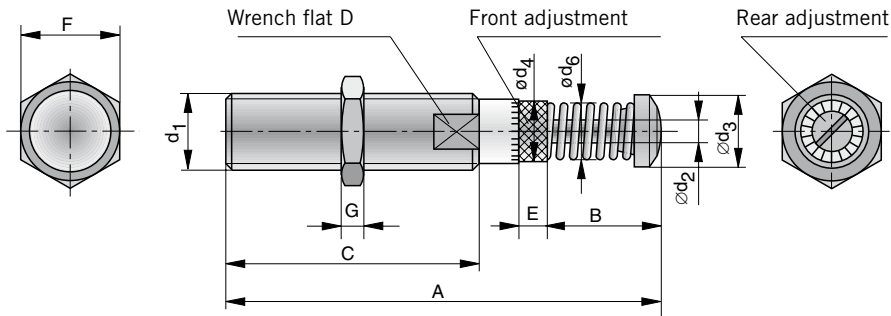

Dimensions (mm) – Universal Flange

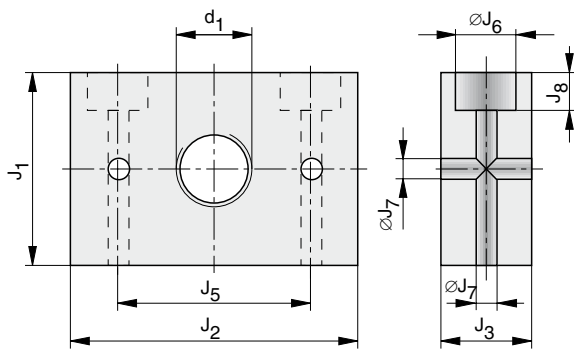

Dimensions (mm) Soft Pad

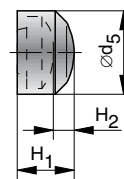

Dimensions (mm) Stop Collar

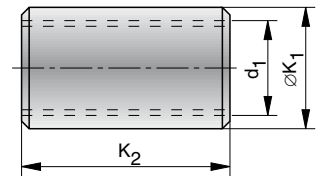

Dimensions Table (mm)

A	B	C	D	d ₁	ød ₂	ød ₃	ød ₄	ød ₅	ød ₆	E	F	G	H ₁	H ₂	J ₁	J ₂	J ₃	J ₄	J ₅	øJ ₆	øJ ₇	J ₈	øK ₁	K ₂
121.2	35.5	61.5	22	M25x1.5 ²⁾	7.9	19.9	22.7	22.1	18.5	12.7	30	8	12.2	6.4	35	47	16	25.5	35	10	5.5	10	31.8	55.6

²⁾ Option: M27x3 thread (d₁)

Order Instructions

Product	Order Instructions	
	Type	Order No.
Shock absorber	SA 3/8 x 1D	7840
Stop collar	SC 25 B	7951
Soft pad	SP 25	7954
Additional mounting nut	LN 25	7959
Universal flange	UM 25	7952

Shock Absorbers

Hydraulic Industrial Shock Absorbers

Type:

- Adjustable

Series SALD SALD 1/2 x 1M

- Stroke 25.4 mm

SALD 1/2 x 2M

- Stroke 50.8 mm

Basic Version with:

- Integral stop collar
- 1 mounting nut

Accessories:

- Rectangular flange

Energy Capacity

Type	Stroke (mm)	Effective Mass (kg)		Max. Energy Capacity (Nm)	
		Min.	Max.	per stroke W_3	per hour W_4
SALD 1/2 x 1M	25.4	4.5	1360	170	85000
SALD 1/2 x 2M	50.8	9.5	2720	340	98000

Technical Data

Characteristic	Unit	Comments
Impact velocity	m/s	0.3 - 4.5
Operating temperature range	°C	-12 to 80
Installation		in any position
Force of return spring	N	SALD 1/2 x 1M: 36 - 82 SALD 1/2 x 2M: 36 - 128
Max. deviation of impacting force from centre axis of shock absorber		±3°
Weight (mass)	kg	SALD 1/2 x 1M: 0,751 SALD 1/2 x 2M: 0,922
Min. mounting strength required	N	13400 ¹⁾
Materials		
Body		Steel, black oxide finish
Piston rod		Steel, hardened, ground, hard-chrome plated
Accessories		Steel, black oxide finish or aluminium, anodized

¹⁾ based on $\frac{2.5 \cdot W_3}{\text{stroke}}$



For product group overview see page 16 + 17
For design and installation notes see from page 4

Dimensions (mm) – Shock Absorbers

Type: SALD 1/2 x 1M, SALD 1/2 x 2M

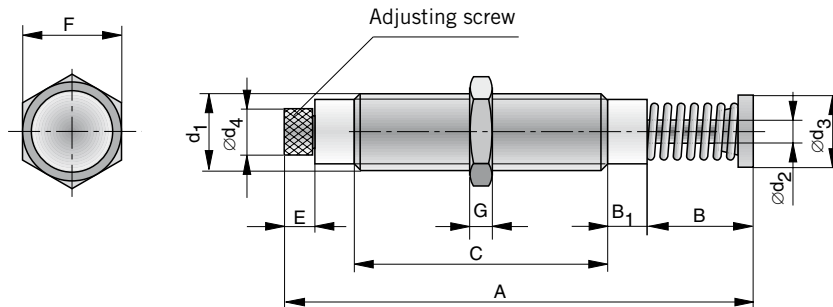

Dimensions (mm) – Rectangular Flange

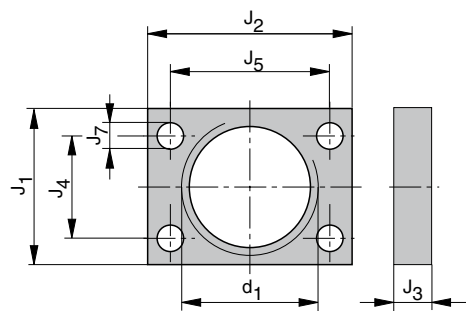

Dimensions Table (mm)

Serie	A	B	B ₁	C	d ₁	ød ₂	ød ₃	ød ₄	E	F	G	J ₁	J ₂	J ₃	J ₄	J ₅	J ₇
SALD 1/2 x 1M	165.1	23.8	6	110	M36x1.5	9.5	25.4	22.5	14.7	41.3	6.7	41	54	9.5	28	42	7
SALD 1/2 x 2M	215.9	49.2	6	134	M36x1.5	9.5	25.4	22.5	14.7	41.3	6.7	41	54	9.5	28	42	7

Order Instructions

Product	Order Instructions	
	Type	Order No.
Shock absorber; stroke 25.4 mm	SALD 1/2 x 1M	7841
Shock absorber, stroke 50.8 mm	SALD 1/2 x 2M	7842
Rectangular flange	RF 1/2-M	7843
Additional mounting nut	LN 1/2-M	7838

Energy Capacity

Type	Stroke (mm)	Effective Mass (kg)		Max. Energy Capacity (Nm)	
		Min.	Max.	per stroke W_3	per hour W_4
SA 1/2 x 1	25.4	4.5	1225	153	84700
SA 1/2 x 2	50.8	9.5	2450	305	98300

Technical Data

Characteristic	Unit	Comments
Impact velocity	m/s	0.3 - 4.5
Operating temperature range	°C	-12 to 80
Installation		in any position
Force of return spring	N	SA 1/2 x 1: 36 - 82 SA 1/2 x 2: 36 - 128
Max. deviation of impacting force from centre axis of shock absorber		±5°
Weight (mass)	kg	SA 1/2 x 1: 0,627 SA 1/2 x 2: 0,8
Min. mounting strength required	N	13300 ¹⁾
Materials		
Body		Steel, black oxide finished
Piston rod		Steel, hardened, ground, hard-chrome plated
Accessories		Steel, black oxide finish or aluminium, anodized

¹⁾ based on $\frac{2.5 \cdot W_3}{\text{stroke}}$

Shock Absorbers

Hydraulic Industrial Shock Absorbers

Type:

- Adjustable

Series SA

SA 1/2 x 1

- Stroke 25.4 mm

SA 1/2 x 2

- Stroke 50.8 mm

Basic Version with:

- 1 mounting nut

Accessories:

- Stop collar
- Rectangular flange
- Soft pad
- Foot mounting



For product overview group see page 16 + 17
For design and installation notes see from page 4

Dimensions (mm) – Shock Absorbers

Type: SA 1/2 x 1, SA 1/2 x 2

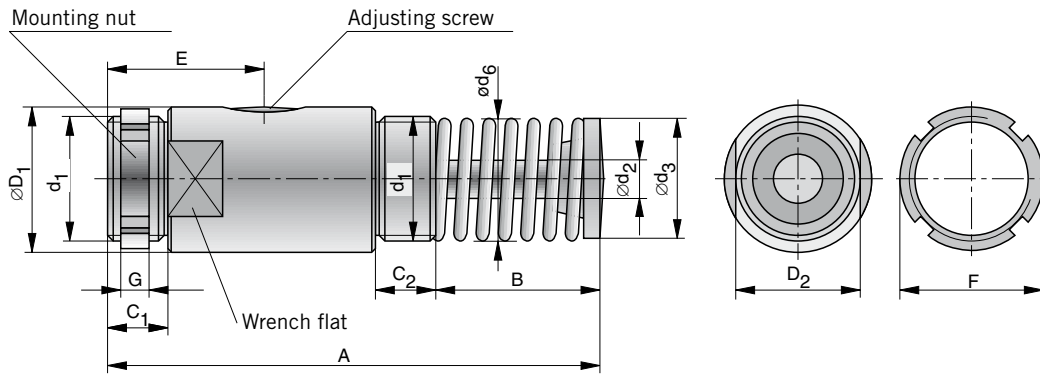

Dimensions (mm) – Rectangular Flange

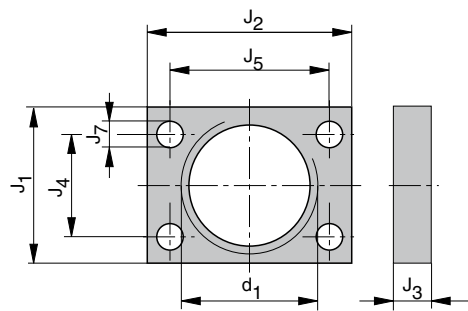

Dimensions (mm) – Stop Collar

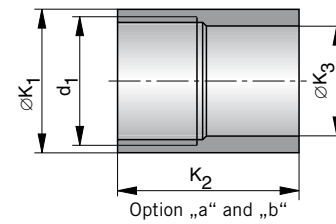

Option „a“ - for rear mounting
Option „b“ - for front mounting

Dimensions (mm) – Foot Mounting

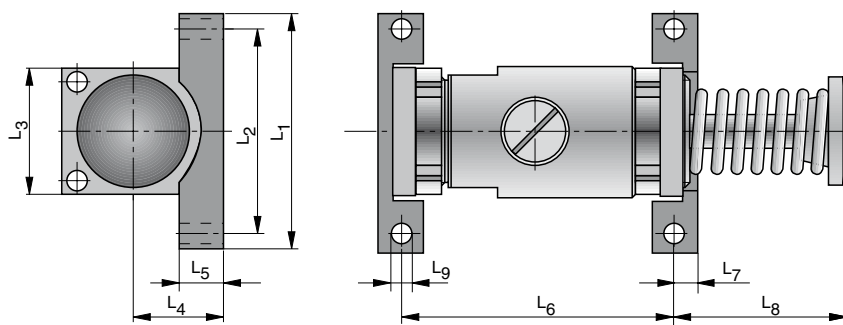

Dimensions (mm) Soft Pad

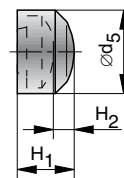

Note:
Cannot be used with stop collar.

Dimensions Table (mm)

Type	A	B	C ₁	C ₂	øD ₁	D ₂	d ₁	ød ₂	ød ₃	ød ₅	ød ₆	E	F	G	H ₁	H ₂	J ₁	J ₂
SA 1/2 x 1	138.1	55.5	16	16	38	35	M33x1.5	9.5	25.4	31.8	25.4	41.3	38	6.4	19.1	11.2	41	54
SA 1/2 x 2	189	81	16	16	38	35	M33x1.5	9.5	25.4	31.8	25.4	41.3	38	6.4	19.1	11.2	41	54

Type	J ₃	J ₄	J ₅	J ₇	øK ₁	K _{2a}	K _{2b}	øK ₃	L ₁	L ₂	L ₃	L ₄	L ₅	L ₆	L ₇	L ₈	L ₉
SA 1/2 x 1	9.5	28	42	7	38.1	47.6	41.3	28.6	69.9	60.3	54	27	12.7	95.3	6.4	49.2	6
SA 1/2 x 2	9.5	28	42	7	38.1	47.6	41.3	28.6	69.9	60.3	54	27	12.7	120.7	6.4	74.6	6

Order Instructions

Product	Order Instructions	
	Type	Order No.
Shock absorber; stroke 25.4 mm	SA 1/2 x 1	7970
Shock absorber; stroke 50.8 mm	SA 1/2 x 2	7975
Soft pad	SP 1/2	7974
Stop collar option a – for rear mounting	SC 1/2A	7971
Stop collar option b – for front mounting	SC 1/2B	7977
Rectangular flange	RF 1/2	7972
Foot mounting	FM 1/2	7973
Additional mounting nut	LN 1/2	7979

Energy Capacity

Typ	Stroke (mm)	Effective Mass (kg)		Max. Energy Capacity (Nm)	
		Min.	Max.	per stroke W_3	per hour W_4
SA 3/4 x 1	25.4	9	8163	339	124300
SA 3/4 x 2	50.8	16	14500	678	146800
SA 3/4 x 3	76	23	20866	1017	180776

Technical Data

Characteristic	Unit	Comments
Impact velocity	m/s	0.3 - 4.5
Operating temperature range	°C	-12 to 80
Installation		in any position
Force of return spring	N	Type: SA 3/4 x 1: 68 - 92 Type: SA 3/4 x 2: 44 - 92 Type: SA 3/4 x 3: 33 - 105
Max. deviation of impacting force from centre axis of shock absorber		±3°
Weight (mass)	kg	Type: SA 3/4 x 1: 1.44 Type: SA 3/4 x 2: 1.8 Type: SA 3/4 x 3: 2.24
Min. mounting strength required	N	29600 ¹⁾
Materials		
Body		Steel, black oxide finish
Piston rod		Steel, hardened, ground, hard-chrome plated
Accessories		Steel, black oxide finish or aluminium, anodized

¹⁾ based on $\frac{2.5 \cdot W_3}{\text{stroke}}$

Shock Absorbers

Hydraulic Industrial Shock Absorbers

Type:

- Adjustable

Series SA

SA 3/4 x 1

- Stroke 25.4 mm

SA 3/4 x 2

- Stroke 50.8 mm

SA 3/4 x 3

- Stroke 76 mm

Basic Version with:

- 1 mounting nut

Accessories:

- Stop collar
- Rectangular flange
- Square flange
- Soft pad
- Foot mounting



For product group overview see page 16 + 17
For design and installation notes see from page 4

Dimensions (mm) – Shock Absorbers

Type: SA 3/4 x 1, SA 3/4 x 2, SA 3/4 x 3

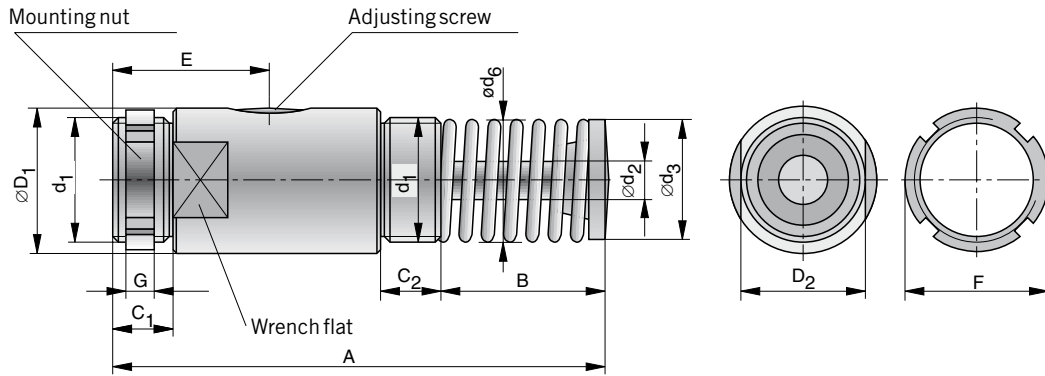

Dimensions (mm) – Rectangular Flange

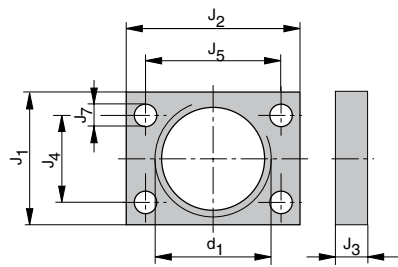

Dimensions (mm) – Square Flange

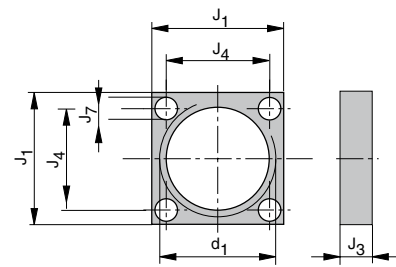

Dimensions (mm) – Stop Collar

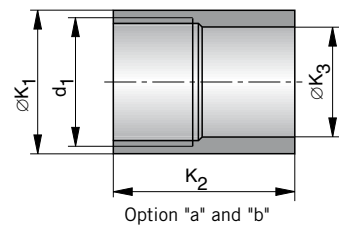

Dimensions (mm) – Soft Pad

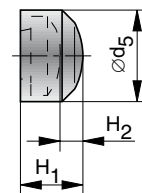

Option „a“ - for rear mounting
Option „b“ - for front mounting

Note:
Cannot be used with stop collar.

Dimensions (mm) – Foot Mounting

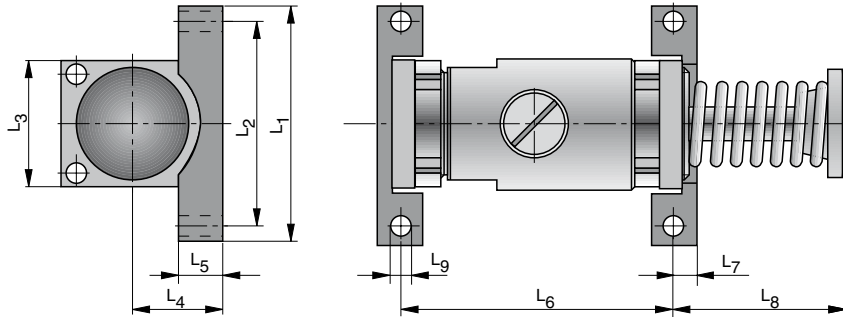

Dimensions Table (mm)

Type	A	B	C ₁	C ₂	øD ₁	D ₂	d ₁	ød ₂	ød ₃	ød ₅	ød ₆	E	F	G	H ₁	H ₂	J ₁	J ₂
SA 3/4 x 1	144.4	50	22.9	23	57.2	50	M42x1.5	12.8	38	44.5	34.7	47.2	57.2	9.5	25.4	17.5	57.2	76.2
SA 3/4 x 2	195.2	75.4	22.9	23	57.2	50	M42x1.5	12.8	38	44.5	34.7	59.5	57.2	9.5	25.4	17.5	57.2	76.2
SA 3/4 x 3	246	100.8	22.9	23	57.2	50	M42x1.5	12.8	38	44.5	38.1	72.6	57.2	9.5	25.4	17.5	57.2	76.2

Type	J ₃	J ₄	J ₅	J ₇	øK ₁	K _{2a}	K _{2b}	øK ₃	L ₁	L ₂	L ₃	L ₄	L ₅	L ₆	L ₇	L ₈	L ₉
SA 3/4 x 1	12.7	41.3	60.3	8.7	57.2	49.2	39.7	41.2	95.3	76.2	57.2	28.6	14.3	85.7	9.5	52.3	8.7
SA 3/4 x 2	12.7	41.3	60.3	8.7	57.2	49.2	39.7	41.2	95.3	76.2	57.2	28.6	14.3	111.1	9.5	77.6	8.7
SA 3/4 x 3	12.7	41.3	60.3	8.7	57.2	49.2	39.7	41.2	95.3	76.2	57.2	28.6	14.3	136.5	9.5	103.2	8.7

Order Instructions

Product	Order Instructions	
	Type	Order No.
Shock absorber; stroke 25.4 mm	SA 3/4 x 1	7980
Shock absorber; stroke 50.8 mm	SA 3/4 x 2	7985
Shock absorber; stroke 76 mm	SA 3/4 x 3	7986
Soft pad	SP 3/4	7984
Stop collar option a – for rear mounting	SC 3/4 A	7981
Stop collar option b – for front mounting	SA 3/4 B	7987
Rectangular flange	RF 3/4	7982
Square flange	SF 3/4	7988
Foot mounting	FM 3/4	7983
Additional mounting nut	LN 3/4	7989

Energy Capacity

Type	Stroke (mm)	Effective Mass (kg)		Max. Energy Capacity (Nm)	
		Min.	Max.	per stroke W_3	per hour W_4
SA 1-1/8 x 2	50.8	54	22680	1808	169478
SA 1-1/8 x 4	102	73	45360	3616	225970
SA 1-1/8 x 6	152	91	68040	5423	282463

Technical Data

Characteristic	Unit	Comments
Impact velocity	m/s	0.3 - 4.5
Operating temperature range	°C	-12 to 80
Installation		in any position
Force of return spring	N	Type: SA 1-1/8 x 2: 80 - 151 Type: SA 1-1/8 x 4: 80 - 200 Type: SA 1-1/8 x 6: 80 - 187
Max. deviation of impacting force from centre axis of shock absorber		±5°
Weight (mass)	kg	Type: SA 1-1/8 x 2: 3.719 Type: SA 1-1/8 x 4: 5.035 Type: SA 1-1/8 x 6: 6.622
Min. mounting strength required	N	68000 ¹⁾
Materials		
Body		Steel, black oxide finish
Piston rod		Steel, hardened, ground, hard-chrome plated
Accessories		Steel, black oxide finish or aluminium, anodized

¹⁾ based on $\frac{2.5 \cdot W_3}{\text{stroke}}$

Shock Absorbers

Hydraulic Industrial Shock Absorbers

Type:
Adjustable

Series SA
SA 1-1/8 x 2
▪ Stroke 50.8 mm

SA 1-1/8 x 4
▪ Stroke 102 mm

SA 1-1/8 x 6
▪ Stroke 152 mm

Basic Version with:
▪ 1 mounting nut

Accessories:
▪ Stop collar
▪ Square flange
▪ Soft pad
▪ Foot mounting



For product group overview see page 16 + 17
For design and installation notes see from page 4

Dimensions (mm) – Shock Absorbers

Type: SA 1-1/8 x 2, SA 1-1/8 x 4, SA 1-1/8 x 6

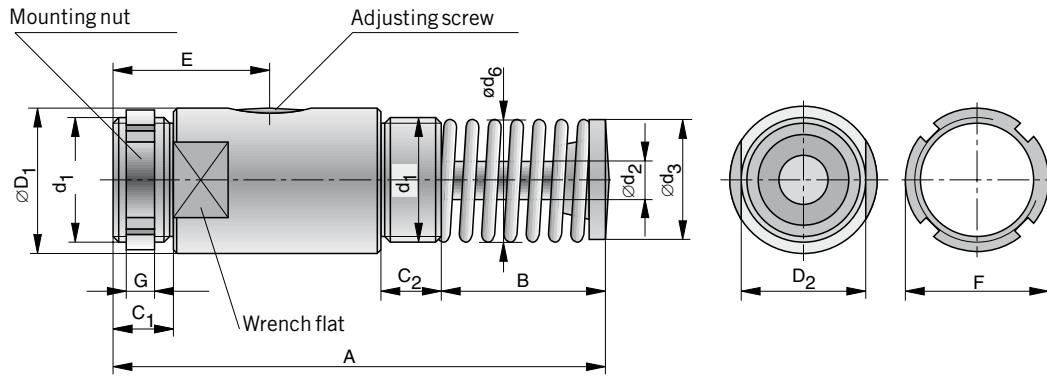

Dimensions (mm) – Square Flange

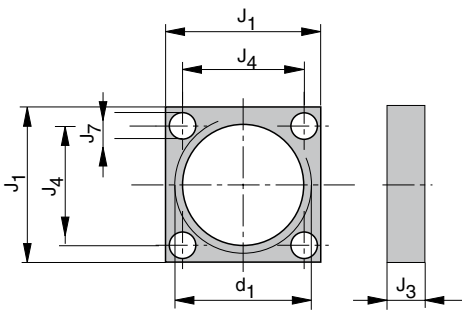

Dimensions (mm) – Stop Collar

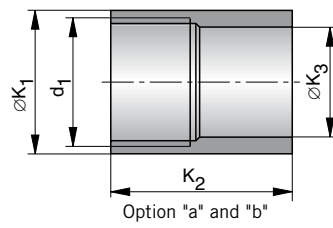

Option „a“ - for rear mounting
Option „b“ - for front mounting

Dimensions (mm) – Foot Mounting

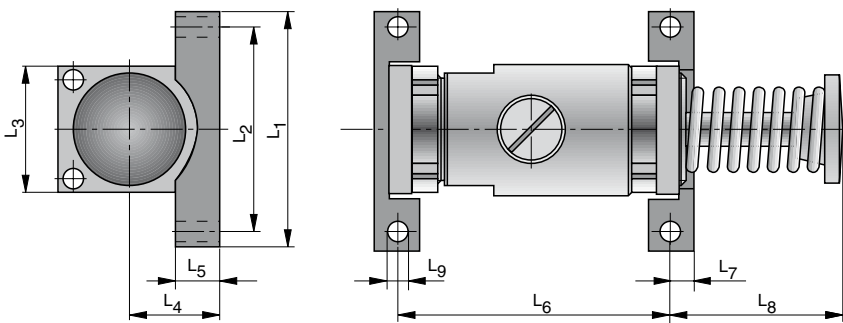

Dimensions (mm) Soft Pad

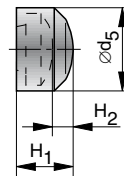

Note:
Cannot be used with stop collar.

Dimensions Table (mm)

Type	A	B	C ₁	C ₂	∅D ₁	D ₂	d ₁	∅d ₂	∅d ₃	∅d ₅	∅d ₆	E	F	G	H ₁	H ₂	J ₁
SA 1-1/8 x 2	225.6	85.9	26.2	26.2	76.2	69.9	M64x2	19.1	50.8	57.2	47.9	69.9	76.2	9.5	25.4	17.5	88.9
SA 1-1/8 x 4	327.2	136.7	26.2	26.2	76.2	69.9	M64x2	19.1	50.8	57.2	50.8	95.3	76.2	9.5	25.4	17.5	88.9
SA 1-1/8 x 6	450.9	209.6	26.2	26.2	76.2	69.9	M64x2	19.1	50.8	57.2	48.3	120.7	76.2	9.5	25.4	17.5	88.9

Type	J ₃	J ₄	J ₇	∅K ₁	K _{2,a}	K _{2,b}	∅K ₃	L ₁	L ₂	L ₃	L ₄	L ₅	L ₆	L ₇	L ₈	L ₉
SA 1-1/8 x 2	15.9	69.9	10.3	76.2	62.7	50	60.3	142.9	123.8	88.9	44.5	19	127	14.3	90.5	10.3
SA 1-1/8 x 4	15.9	69.9	10.3	76.2	62.7	50	60.3	142.9	123.8	88.9	44.5	19	177.8	14.3	141.3	10.3
SA 1-1/8 x 6	15.9	69.9	10.3	76.2	84.9	72.2	60.3	142.9	123.8	88.9	44.5	19	228.5	14.3	214.3	10.3

Order Instructions

Product	Order Instructions	
	Type	Order No.
Shock absorber; stroke 50.8 mm	SA 1-1/8 x 2	7990
Shock absorber; stroke 102 mm	SA 1-1/8 x 4	7995
Shock absorber; stroke 152 mm	SA 1-1/8 x 6	7996
Soft pad	SP 1-1/8	7994
Square flange	SF 1-1/8	7998
Foot mounting	FM 1-1/8	7993
Additional mounting nut	LN 1-1/8	7999
Stop collar option a – for SA 1-1/8 x 2, SA 1-1/8 x 4	SC 1-1/8 A	7991
Stop collar option b – for SA 1-1/8 x 2, SA 1-1/8 x 4	SC 1-1/8 B	7997
Stop collar option a – for SA 1-1/8 x 6	SC 1-1/8 A	7891
Stop collar option b – for SA 1-1/8 x 6	SC 1-1/8 B	7897

Energy Capacity

Type	Stroke (mm)	Effective Mass (kg)		Max. Energy Capacity (Nm)	
		Min.	Max.	per stroke W_3	per hour W_4
SA-A 3/4 x 1	25.4	27	3600	290	184000
SA-A 3/4 x 2	50.8	43	6350	600	230000
SA-A 3/4 x 3	76	55	9500	890	276000

Technical Data

Characteristic	Unit	Comments
Impact velocity	m/s	0.3 - 4.5
Operating temperature range	°C	-12 to 80
Installation		in any position
Max. deviation of impacting force from centre axis of shock absorber		±5°
Weight (mass)	kg	Type: SA-A 3/4 x 1: 1.43 Type: SA-A 3/4 x 2: 1.79 Type: SA-A 3/4 x 3: 2.23
Min. mounting strength required	N	29600 ¹⁾
Materials		
Body		Steel, black oxide finish
Piston rod		Steel, hardened, ground, hard-chrome plated
Accessories		Steel, black oxide finish or aluminium, anodized

¹⁾ based on $\frac{2.5 \cdot W_3}{\text{stroke}}$

Shock Absorbers

Hydraulic Industrial Shock Absorbers

Type:

- Adjustable, without return spring, for use with external air-oil tank

Series SA-A

SA-A 3/4 x 1

- Stroke 25.4 mm

SA-A 3/4 x 2

- Stroke 50.8 mm

SA-A 3/4 x 3

- Stroke 76 mm

Basic Version with:

- 1 mounting nut

Accessories:

- Air-oil tank, Type AOT-1
- Stop collar
- Rectangular flange
- Square flange
- Soft pad
- Foot mounting



For product group overview see page 16 + 17
For design and installation notes see from page 4

Dimensions (mm) – Shock Absorber for Connection to Air-Oil Tank

Type: SA-A 3/4 x 1, SA-A 3/4 x 2, SA-A 3/4 x 3

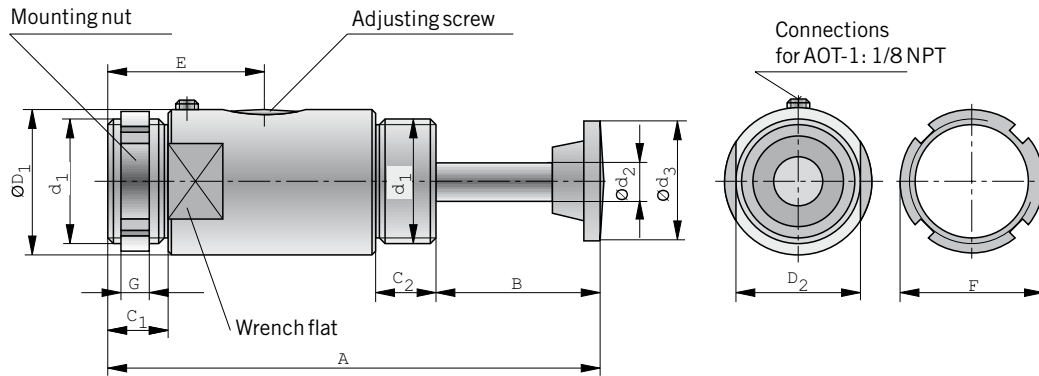

Dimensions (mm) – Rectangular Flange

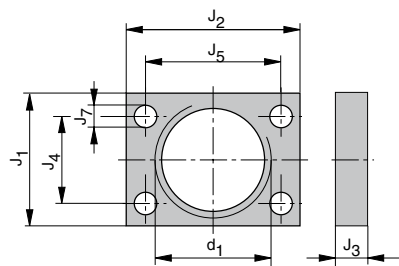

Dimensions (mm) – Square Flange

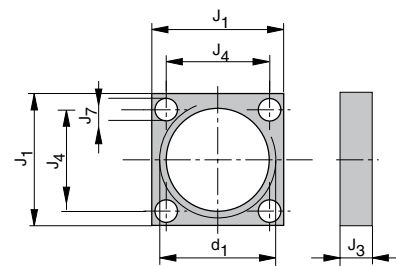

Dimensions (mm) – Foot Mounting

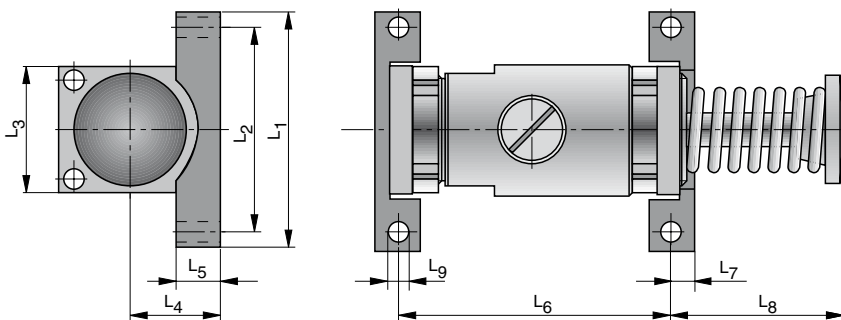

Dimensions (mm) – Stop Collar

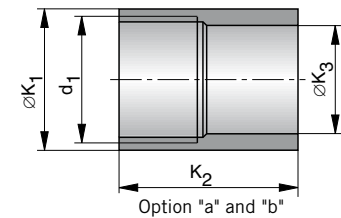

Option „a“ - for rear mounting
Option „b“ - for front mounting

Dimensions (mm) – Air-Oil-Tank Type AOT-1

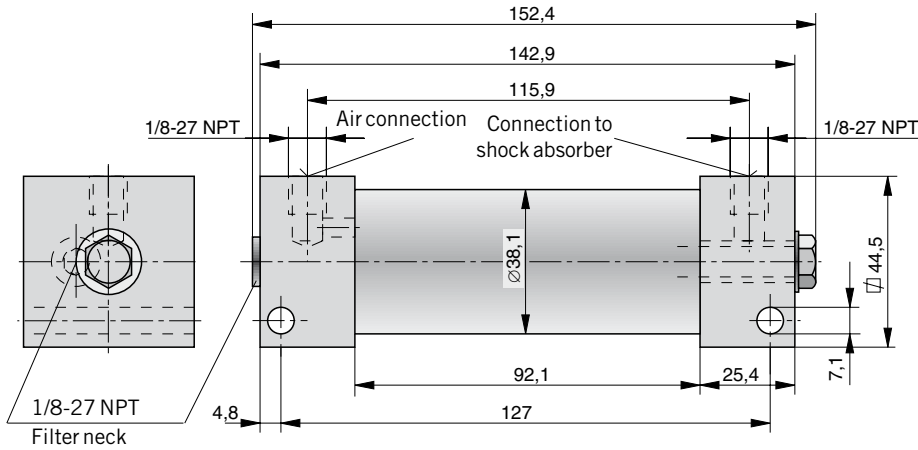

Dimensions (mm) Soft Pad

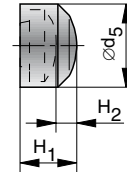

Note:
Cannot be used with stop collar.

Dimensions Table (mm)

Type	A	B	C ₁	C ₂	øD ₁	D ₂	d ₁	ød ₂	ød ₃	ød ₅	E	F	G	H ₁	H ₂	J ₁	J ₂
SA-A 3/4 x 1	144.4	50	22.9	23	57.2	50	M42x1.5	14.3	38	44.5	47.2	57.2	9.5	25.4	17.5	57.2	76.2
SA-A 3/4 x 2	195.2	75.4	22.9	23	57.2	50	M42x1.5	14.3	38	44.5	59.5	57.2	9.5	25.4	17.5	57.2	76.2
SA-A 3/4 x 3	246	100.8	22.9	23	57.2	50	M42x1.5	14.3	38	44.5	72.6	57.2	9.5	25.4	17.5	57.2	76.2

Type	J ₃	J ₄	J ₅	J ₇	øK ₁	K _{2,a}	K _{2,b}	øK ₃	L ₁	L ₂	L ₃	L ₄	L ₅	L ₆	L ₇	L ₈	L ₉
SA-A 3/4 x 1	12.7	41.3	60.3	8.7	57.2	49.2	39.7	41.2	95.3	76.2	57.2	28.6	14.3	85.7	9.5	52.3	8.7
SA-A 3/4 x 2	12.7	41.3	60.3	8.7	57.2	49.2	39.7	41.2	95.3	76.2	57.2	28.6	14.3	111.1	9.5	77.6	8.7
SA-A 3/4 x 3	12.7	41.3	60.3	8.7	57.2	49.2	39.7	41.2	95.3	76.2	57.2	28.6	14.3	136.5	9.5	103.2	8.7

Order Instructions

Product	Order Instructions	
	Type	Order Nol
Shock absorber; stroke 25.4 mm	SA-A 3/4 x 1	7887
Shock absorber; stroke 50.8 mm	SA-A 3/4 x 2	7888
Shock absorber; stroke 76 mm	SA-A 3/4 x 3	7889
Soft pad	SP-3/4	7984
Square flange	SF-3/4	7988
Rectangular flange	RF-3/4	7982
Foot mounting	FM-3/4	7983
Additional mounting nut	LN-3/4	7989
Stop collar option a – for SA-A 3/4 x 1, SA-A 3/4 x 2, SA-A 3/4 x 3	SC-A 3/4	7981
Stop collar option b – for SA-A 3/4 x 1, SA-A 3/4 x 2, SA-A 3/4 x 3	SC-B 3/4	7987
Air-oil tank	AOT-1	7898

Energy Capacity

Type	Stroke (mm)	Effective Mass (kg)		Max. Energy Capacity (Nm)	
		Min.	Max.	per stroke W_3	per hour W_4
SA-A 1-1/8 x 2	50.8	72	13000	1380	345000
SA-A 1-1/8 x 4	102	118	18200	2700	460000
SA-A 1-1/8 x 6	152	200	32000	4150	575000

Technical Data

Characteristic	Unit	Comments
Impact velocity	m/s	0.3 - 4.5
Operating temperature range	°C	-12 to 80
Installation		in any position
Max. deviation of impacting force from centre axis of shock absorber		±5°
Weight (mass)	kg	Type: SA-A 1-1/8 x 2: 3.709 Type: SA-A 1-1/8 x 4: 5.025 Type: SA-A 1-1/8 x 6: 6.612
Min. mounting strength required	N	68000 ¹⁾
Materials		
Body		Steel, black oxide finish
Piston rod		Steel, hardened, ground, hard-chrome plated
Accessories		Steel, black oxide finish or aluminium, anodized Air-oil tank: high-tensile steel

¹⁾ based on $\frac{2.5 \cdot W_3}{\text{stroke}}$

Shock Absorbers

Hydraulic Industrial Shock Absorbers

Type:

- Adjustable, without return spring, for use with external air-oil tank

Series SA-A

SA-A 1-1/8 x 2

- Stroke 50.8 mm

SA-A 1-1/8 x 4

- Stroke 102 mm

SA-A 1-1/8 x 6

- Stroke 152 mm

Basic Version with:

- 1 mounting nut

Accessories:

- Air-oil tank, Type AOT-3
- Stop collar
- Square flange
- Soft pad
- Foot mounting



For product group overview see page 16 + 17
For design and installation notes see from page 4

Dimensions (mm) – Shock Absorbers

Type: SA-A 1-1/8 x 2, SA-A 1-1/8 x 4, SA-A 1-1/8 x 6

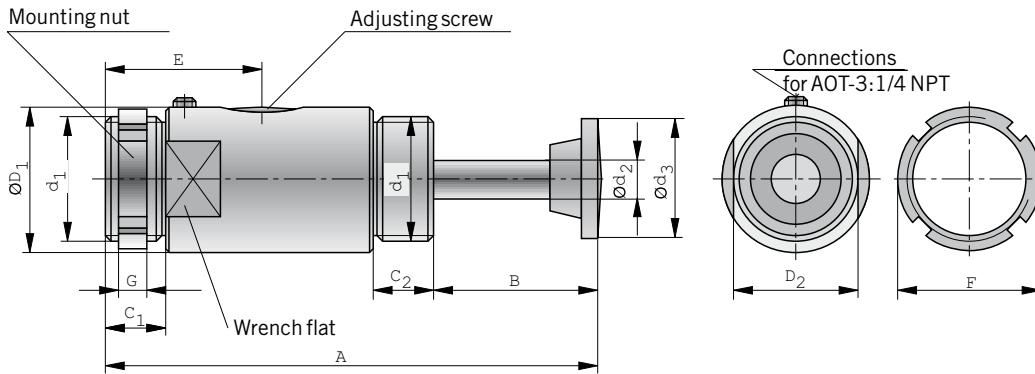

Dimensions (mm) – Square Flange

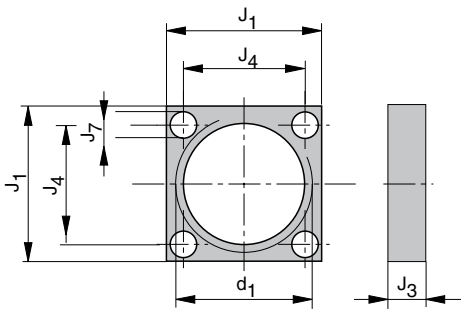

Dimensions (mm) – Stop Collar

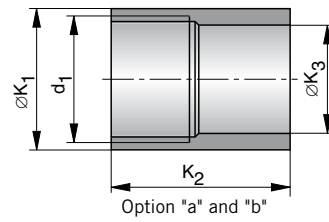

Option „a“ - for rear mounting
Option „b“ - for front mounting

Dimensions (mm) – Food mounting

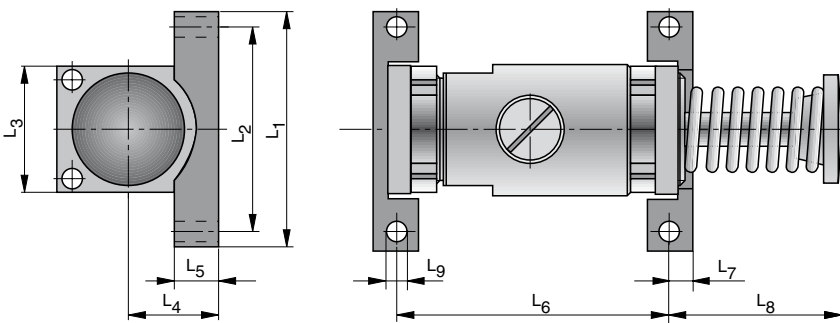

Dimensions (mm) Soft Pad

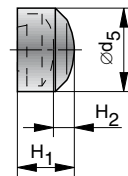

Note:
Cannot be used with stop collar.

Dimensions (mm) – Air-Oil Tank AOT3

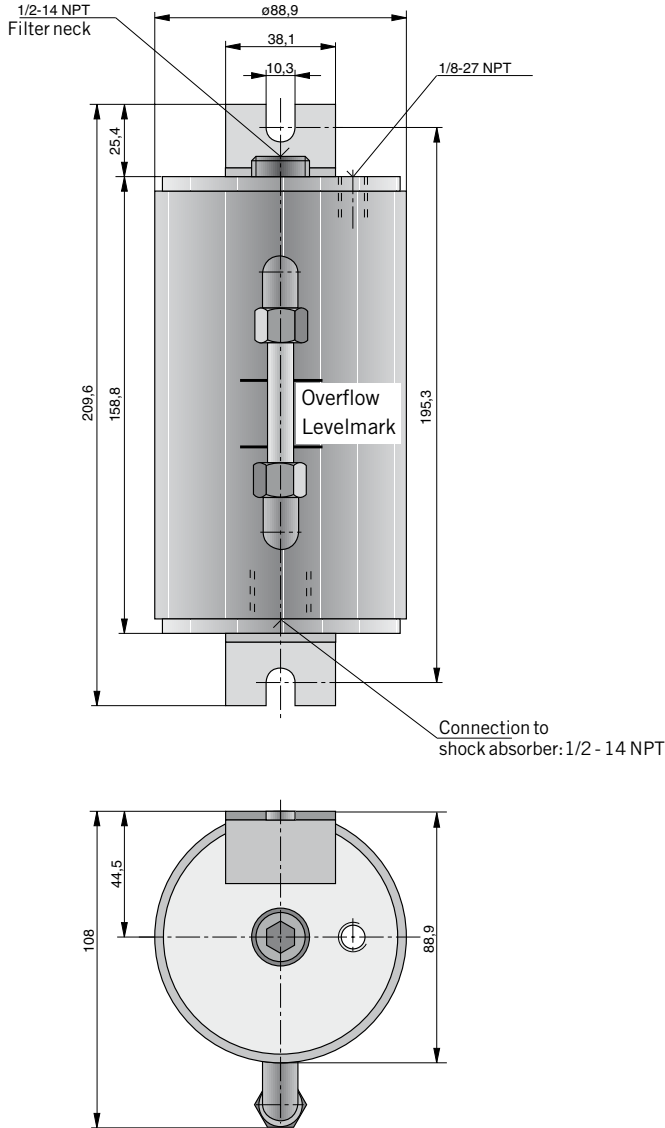

Dimensions Table (mm)

Type	A	B	C ₁	C ₂	$\varnothing D_1$	D ₂	d ₁	$\varnothing d_2$	$\varnothing d_3$	$\varnothing d_5$	E	F	G	H ₁	H ₂	J ₁
SA-A 1-1/8 x 2	225.6	85.9	26.2	26.2	76.2	69.9	M64x2	19.1	50.8	57.2	69.9	76.2	9.5	25.4	17.5	88.9
SA-A 1-1/8 x 4	327.2	136.7	26.2	26.2	76.2	69.9	M64x2	19.1	50.8	57.2	95.3	76.2	9.5	25.4	17.5	88.9
SA-A 1-1/8 x 6	450.9	209.6	26.2	26.2	76.2	69.9	M64x2	19.1	50.8	57.2	120.7	76.2	9.5	25.4	17.5	88.9

Type	J ₃	J ₄	J ₇	$\varnothing K_1$	K _{2a}	K _{2b}	$\varnothing K_3$	L ₁	L ₂	L ₃	L ₄	L ₅	L ₆	L ₇	L ₈	L ₉
SA-A 1-1/8 x 2	15.9	69.9	10.3	76.2	62.7	50	60.3	142.9	123.8	88.9	44.5	19	127	14.3	90.5	10.3
SA-A 1-1/8 x 4	15.9	69.9	10.3	76.2	62.7	50	60.3	142.9	123.8	88.9	44.5	19	177.8	14.3	141.3	10.3
SA-A 1-1/8 x 6	15.9	69.9	10.3	76.2	84.9	72.2	60.3	142.9	123.8	88.9	44.5	19	228.5	14.3	214.3	10.3

Order Instructions

Product	Order Instructions	
	Type	Order No.
Shock absorber; stroke 50.8 mm	SA-A 1-1/8 x 2	7880
Shock absorber; stroke 102 mm	SA-A 1-1/8 x 4	7885
Shock absorber; stroke 152 mm	SA-A 1-1/8 x 6	7886
Soft pad	SP 1-1/8	7994
Square flange	SF 1-1/8	7998
Foot mounting	FM 1-1/8	7993
Additional mounting nut	LN 1-1/8	7999
Stop collar option a – SA-A 1-1/8 x 2, SA-A 1-1/8 x 4	SC 1-1/8 A	7991
Stop collar option b – SA-A 1-1/8 x 2, SA-A 1-1/8 x 4	SC 1-1/8 B	7997
Stop collar option a – SA-A 1-1/8 x 6	SC 1-1/8 A	7891
Stop collar option b – SA-A 1-1/8 x 6	SC 1-1/8 B	7897
Air-oil tank	AOT-3	7899

Parker Worldwide

AE – UAE, Dubai
Tel: +971 4 8127100
parker.me@parker.com

AR – Argentina, Buenos Aires
Tel: +54 3327 44 4129

AT – Austria, Wiener Neustadt
Tel: +43 (0)2622 23501-0
parker.austria@parker.com

AT – Eastern Europe, Wiener Neustadt
Tel: +43 (0)2622 23501 900
parker.easteurope@parker.com

AU – Australia, Castle Hill
Tel: +61 (0)2-9634 7777

AZ – Azerbaijan, Baku
Tel: +994 50 2233 458
parker.azerbaijan@parker.com

BE/LU – Belgium, Nivelles
Tel: +32 (0)67 280 900
parker.belgium@parker.com

BR – Brazil, Cachoeirinha RS
Tel: +55 51 3470 9144

BY – Belarus, Minsk
Tel: +375 17 209 9399
parker.belarus@parker.com

CA – Canada, Milton, Ontario
Tel: +1 905 693 3000

CH – Switzerland, Etoy
Tel: +41 (0)21 821 87 00
parker.switzerland@parker.com

CL – Chile, Santiago
Tel: +56 2 623 1216

CN – China, Shanghai
Tel: +86 21 2899 5000

CZ – Czech Republic, Klecany
Tel: +420 284 083 111
parker.czechrepublic@parker.com

DE – Germany, Kaarst
Tel: +49 (0)2131 4016 0
parker.germany@parker.com

DK – Denmark, Ballerup
Tel: +45 43 56 04 00
parker.denmark@parker.com

ES – Spain, Madrid
Tel: +34 902 330 001
parker.spain@parker.com

FI – Finland, Vantaa
Tel: +358 (0)20 753 2500
parker.finland@parker.com

FR – France, Contamine s/Arve
Tel: +33 (0)4 50 25 80 25
parker.france@parker.com

GR – Greece, Athens
Tel: +30 210 933 6450
parker.greece@parker.com

HK – Hong Kong
Tel: +852 2428 8008

HU – Hungary, Budapest
Tel: +36 1 220 4155
parker.hungary@parker.com

IE – Ireland, Dublin
Tel: +353 (0)1 466 6370
parker.ireland@parker.com

IN – India, Mumbai
Tel: +91 22 6513 7081-85

IT – Italy, Corsico (MI)
Tel: +39 02 45 19 21
parker.italy@parker.com

JP – Japan, Tokyo
Tel: +81 (0)3 6408 3901

KR – South Korea, Seoul
Tel: +82 2 559 0400

KZ – Kazakhstan, Almaty
Tel: +7 7272 505 800
parker.easteurope@parker.com

LV – Latvia, Riga
Tel: +371 6 745 2601
parker.latvia@parker.com

MX – Mexico, Apodaca
Tel: +52 81 8156 6000

MY – Malaysia, Shah Alam
Tel: +60 3 7849 0800

NL – The Netherlands, Oldenzaal
Tel: +31 (0)541 585 000
parker.nl@parker.com

NO – Norway, Asker
Tel: +47 66 75 34 00
parker.norway@parker.com

NZ – New Zealand, Mt Wellington
Tel: +64 9 574 1744

PL – Poland, Warsaw
Tel: +48 (0)22 573 24 00
parker.poland@parker.com

PT – Portugal, Leca da Palmeira
Tel: +351 22 999 7360
parker.portugal@parker.com

RO – Romania, Bucharest
Tel: +40 21 252 1382
parker.romania@parker.com

RU – Russia, Moscow
Tel: +7 495 645-2156
parker.russia@parker.com

SE – Sweden, Spånga
Tel: +46 (0)8 59 79 50 00
parker.sweden@parker.com

SG – Singapore
Tel: +65 6887 6300

SK – Slovakia, Banská Bystrica
Tel: +421 484 162 252
parker.slovakia@parker.com

SL – Slovenia, Novo Mesto
Tel: +386 7 337 6650
parker.slovenia@parker.com

TH – Thailand, Bangkok
Tel: +662 717 8140

TR – Turkey, Istanbul
Tel: +90 216 4997081
parker.turkey@parker.com

TW – Taiwan, Taipei
Tel: +886 2 2298 8987

UA – Ukraine, Kiev
Tel: +380 44 494 2731
parker.ukraine@parker.com

UK – United Kingdom, Warwick
Tel: +44 (0)1926 317 878
parker.uk@parker.com

US – USA, Cleveland
Tel: +1 216 896 3000

VE – Venezuela, Caracas
Tel: +58 212 238 5422

ZA – South Africa, Kempton Park
Tel: +27 (0)11 961 0700
parker.southafrica@parker.com

